

**Initial Business Case Analysis of Two
Integrated Heat Pump HVAC Systems
for Near-Zero-Energy Homes – Update to
Include Evaluation of Impact of a
Humidifier Option**

Van Baxter

DOCUMENT AVAILABILITY

Reports produced after January 1, 1996, are generally available free via the U.S. Department of Energy (DOE) Information Bridge:

Web site: <http://www.osti.gov/bridge>

Reports produced before January 1, 1996, may be purchased by members of the public from the following source:

National Technical Information Service
5285 Port Royal Road
Springfield, VA 22161
Telephone: 703-605-6000 (1-800-553-6847)
TDD: 703-487-4639
Fax: 703-605-6900
E-mail: info@ntis.fedworld.gov
Web site: <http://www.ntis.gov/support/ordernowabout.htm>

Reports are available to DOE employees, DOE contractors, Energy Technology Data Exchange (ETDE) representatives, and International Nuclear Information System (INIS) representatives from the following source:

Office of Scientific and Technical Information
P.O. Box 62
Oak Ridge, TN 37831
Telephone: 865-576-8401
Fax: 865-576-5728
E-mail: reports@adonis.osti.gov
Web site: <http://www.osti.gov/contact.html>

This report was prepared as an account of work sponsored by an agency of the United States Government. Neither the United States government nor any agency thereof, nor any of their employees, makes any warranty, express or implied, or assumes any legal liability or responsibility for the accuracy, completeness, or usefulness of any information, apparatus, product, or process disclosed, or represents that its use would not infringe privately owned rights. Reference herein to any specific commercial product, process, or service by trade name, trademark, manufacturer, or otherwise, does not necessarily constitute or imply its endorsement, recommendation, or favoring by the United States Government or any agency thereof. The views and opinions of authors expressed herein do not necessarily state or reflect those of the United States Government or any agency thereof.

Engineering Science and Technology Division

**Initial Business Case Analysis of Two Integrated
Heat Pump HVAC Systems for Near-Zero-Energy
Homes – Update to Include Evaluation of Impact
of a Humidifier Option**

Van Baxter
Oak Ridge National Laboratory

February 2007

Prepared by
Oak Ridge National Laboratory
P.O. Box 2008, Oak Ridge, Tennessee 37831-6285,
managed by UT-Battelle, LLC
for the
U.S. Department of Energy under contract DE-AC05-00OR22725

CONTENTS

| | |
|--|----|
| LIST OF FIGURES | iv |
| LIST OF TABLES | iv |
| ACKNOWLEDGEMENTS | v |
| 1. INTRODUCTION | 1 |
| 2. HOUSE DESCRIPTIONS | 2 |
| 3. DESCRIPTION OF HVAC SYSTEM OPTIONS | 3 |
| 3.1 Baseline | 3 |
| 3.2 Centrally Ducted Air-Source Integrated Heat Pump (AS-IHP) | 4 |
| 3.3 Centrally Ducted Ground-Source Integrated Heat Pump (GS-IHP) | 5 |
| 4. ANALYSIS APPROACH | 5 |
| 5. SYSTEMS ENERGY CONSUMPTION RESULTS | 6 |
| 6. SYSTEM COST ESTIMATES and PAYBACK COMPARISONS | 12 |
| 6.1 Baseline System | 12 |
| 6.2 AS-IHP | 12 |
| 6.3 GS-IHP | 14 |
| 6.4 GS-IHP/SWS | 15 |
| 7. CONCLUSIONS AND RECOMMENDATIONS | 16 |
| REFERENCES | 17 |

LIST OF FIGURES

| | |
|---|----|
| Fig. 1. Representative humidifier installation..... | 4 |
| Fig. 2. Conceptual diagram of a central forced-air electric air-source integrated heat pump, showing operation in space-cooling mode..... | 5 |
| Fig. 3. Space and outdoor RH levels in Chicago for NZE house - baseline HVAC system, no humidifier..... | 10 |
| Fig. 4. Space and outdoor RH levels in Chicago for NZE house - baseline HVAC system, with humidifier. | 10 |
| Fig. 5. Space and outdoor RH levels in Chicago for NZE house – AS-IHP with humidifier..... | 11 |
| Fig. 6. Space and outdoor RH levels in Chicago for NZE house – GS-IHP with humidifier..... | 11 |
| Fig. 7. Schematic of AS-IHP system, combined space cooling and dedicated water heating mode shown. | 13 |
| Fig. 8. Schematic of GS-IHP system, dedicated dehumidification mode shown. | 14 |

LIST OF TABLES

| | |
|--|----|
| Table 1. IHP performance (by individual load) vs. baseline system in NZEH (reprinted from Baxter 2006a; with corrections as noted in text)..... | 7 |
| Table 2. IHP performance vs. baseline system in NZE house (with humidifier) | 9 |
| Table 3. Estimated installed costs for NZE house baseline HVAC/WH/DH system in 2006 dollars (from Baxter 2006a)..... | 12 |
| Table 4. Estimated installed costs for NZE house AS-IHP system without humidifier in 2006 dollars (from Baxter 2006a; with corrections)..... | 13 |
| Table 5. Estimated simple payback for NZE house AS-IHP system vs. baseline, both with humidifier (2006 dollars) | 14 |
| Table 6. Estimated installed costs for NZE house GS-IHP system without humidifier in 2006 dollars – assuming vertical bore ground HX at \$1000/ton installed (from Baxter 2006a: with corrections) | 15 |

Table 7. Estimated simple payback for NZE house GS-IHP system vs. baseline, both with humidifier (2006 dollars).....15

Table 8. Estimated installed costs for NZE house SWS-enhanced GS-IHP system without humidifier in 2006 dollars (from Baxter 2006a; with corrections).....16

Table 9. Estimated simple payback for NZE house GS-IHP/SWS system vs. baseline, both with humidifier (2006 dollars).....16

ACKNOWLEDGEMENTS

The author would like to acknowledge that following persons contributed significantly to the content, supporting analysis, or preparation of this report:

From Oak Ridge National Laboratory — Keith Rice, Richard Murphy, and Patrick Hughes contributed to the content and Erica Atkin to the preparation of this report.

From Thermal Energy System Specialists — Jeff Thornton, Tim McDowell, and David Bradley contributed to the supporting analysis.

1. INTRODUCTION

The long range strategic goal of the Department of Energy's Building Technologies (DOE/BT) Program is to create, by 2020, technologies and design approaches that enable the construction of net-zero energy homes at low incremental cost (DOE/BT 2005). A net zero energy home (NZEH) is a residential building with greatly reduced needs for energy through efficiency gains, with the balance of energy needs supplied by renewable technologies. While initially focused on new construction, these technologies and design approaches are intended to have application to buildings constructed before 2020 as well resulting in substantial reduction in energy use for all building types and ages. DOE/BT's Emerging Technologies (ET) team is working to support this strategic goal by identifying and developing advanced heating, ventilating, air-conditioning, and water heating (HVAC/WH) technology options applicable to NZEHs.

In FY05 ORNL conducted an initial Stage 1 (Applied Research) scoping assessment of HVAC/WH systems options for future NZEHs to help DOE/BT identify and prioritize alternative approaches for further development. Eleven system concepts with central air distribution ducting and nine multi-zone systems were selected and their annual and peak demand performance estimated for five locations: Atlanta (mixed-humid), Houston (hot-humid), Phoenix (hot-dry), San Francisco (marine), and Chicago (cold). Performance was estimated by simulating the systems using the TRNSYS simulation engine (Solar Energy Laboratory et al. 2006) in two 1800-ft² houses — a Building America (BA) benchmark house and a prototype NZEH taken from BEopt results at the take-off (or crossover) point (i.e., a house incorporating those design features such that further progress towards ZEH is through the addition of photovoltaic power sources, as determined by current BEopt analyses conducted by NREL). Results were summarized in a project report, *HVAC Equipment Design options for Near-Zero-Energy Homes – A Stage 2 Scoping Assessment*, ORNL/TM-2005/194 (Baxter 2005). The 2005 study report describes the HVAC options considered, the ranking criteria used, and the system rankings by priority.

In 2006, the two top-ranked options from the 2005 study, air-source and ground-source versions of a centrally ducted integrated heat pump (IHP) system, were subjected to an initial business case study. The IHPs were subjected to a more rigorous hourly-based assessment of their performance potential compared to a baseline suite of equipment of legally minimum efficiency that provided the same heating, cooling, water heating, demand dehumidification, and ventilation services as the IHPs. Results were summarized in a project report, *Initial Business Case Analysis of Two Integrated Heat Pump HVAC Systems for Near-Zero-Energy Homes*, ORNL/TM-2006/130 (Baxter 2006a). The present report is an update to that document which summarizes results of an analysis of the impact of adding a humidifier to the HVAC system to maintain minimum levels of space relative humidity (RH) in winter. The space RH in winter has direct impact on occupant comfort and on control of dust mites, many types of disease bacteria, and “dry air” electric shocks. Chapter 8 in ASHRAE's 2005 Handbook of Fundamentals (HOF) suggests a 30% lower limit on RH for indoor temperatures in the range of ~68-69F based on comfort (ASHRAE 2005). Table 3 in chapter 9 of the same reference

suggests a 30-55% RH range for winter as established by a Canadian study of exposure limits for residential indoor environments (EHD 1987). Harriman, et al (2001) note that for RH levels of 35% or higher, electrostatic shocks are minimized and that dust mites cannot live at RH levels below 40%. They also indicate that many disease bacteria life spans are minimized when space RH is held within a 30-60% range. From the foregoing it is reasonable to assume that a winter space RH range of 30-40% would be an acceptable compromise between comfort considerations and limitation of growth rates for dust mites and many bacteria.

In addition it reports some corrections made to the simulation models used in order to correct some errors in the TRNSYS building model for Atlanta and in the refrigerant pressure drop calculation in the water-to-refrigerant evaporator module of the ORNL Heat Pump Design Model (HPDM) used for the IHP analyses. These changes resulted in some minor differences between IHP performance as reported in Baxter (2006) and in this report. Where these occur, they are highlighted in [blue type](#).

2. HOUSE DESCRIPTIONS

Prototype NZE houses were used for the IHP energy savings estimation analyses in this update. These were as determined in July 2005 by NREL using their Building Energy Optimization (BEopt) analyses tool (Christensen 2005, Anderson, et al 2004) at the photovoltaic (PV) take-off point.

TRNSYS representations were developed for the NZE houses. Thermostat temperature control was single-zone with set points of 71°F heating, 76°F cooling, and 120°F water heating as provided in the DOE 2.2 BDL files from NREL. In the BEopt analyses, it was assumed that the occupants of the house would open windows to take advantage of free cooling whenever ambient air temperature was low enough during the cooling season. For the TRNSYS representations we elected to do the simulations with no window openings. This report includes evaluation of the impact of adding a humidifier to the house HVAC system to maintain minimum winter RH levels. Based on the factors discussed in the Introduction, above, a winter RH set point of 34% with a deadband of $\pm 4\%$ (on at 30% RH, off at 38% RH) was established for humidifier control in the simulation process.

3. DESCRIPTION OF HVAC SYSTEM OPTIONS

3.1 *Baseline*

A standard split-system (separate indoor and outdoor sections), air-to-air heat pump provides space heating and cooling under control of a central thermostat that senses indoor space temperature. It also provides dehumidification when operating in space cooling mode but does not separately control space humidity. Rated system efficiencies were set at the DOE-minimum required levels (SEER 13 and HSPF 7.7) in effect for

2006. Water heating is provided using a standard 50 gallon capacity electric storage water heater with energy factor (EF) set at the current DOE-minimum requirement (EF = 0.90) for this size WH. Ventilation meeting the requirements of ASHRAE Standard 62.2-2004 (ASHRAE 2004) is provided using a central exhaust fan. A separate, standalone dehumidifier (DH) representative of the majority of unit sales in the US is included as well to meet house dehumidification needs during spring, summer, and fall whenever the central heat pump is not running to provide space cooling. Baxter (2006a) provides a fuller description of the dehumidifier sizing philosophy followed.

A whole-house humidifier similar to a model offered by Research Products Corporation (<http://aprilair.com/index.php?znfAction=ProductDetails&category=5&item=550>) was included with the system to provide the winter humidification function. Product data for the model (sized for <3000 ft², tightly constructed homes) specifies a fixed water input flow of 0.5 gal/hr when operating. Hot water from the DHW tank was used for the humidifier supply based on manufacturer specifications for application with heat pump systems (<http://aprilair.com/themes/aa/en/manuals/400.pdf>). Figure 1 provides an illustration representative of how such a humidifier might be installed. Some of the indoor air stream is diverted or bypassed through the humidifier where water is evaporated from a distribution pad. Energy consumption of the system will be increased compared to operation without a humidifier in two ways – 1) extra water heater consumption to cover the humidifier water usage and 1) extra heat pump energy use to overcome the cooling effect of the water evaporation on the air stream. The type humidifier adopted for the analyses reported herein consumes no power other than a negligibly small amount needed to operate the water flow control solenoid valve.

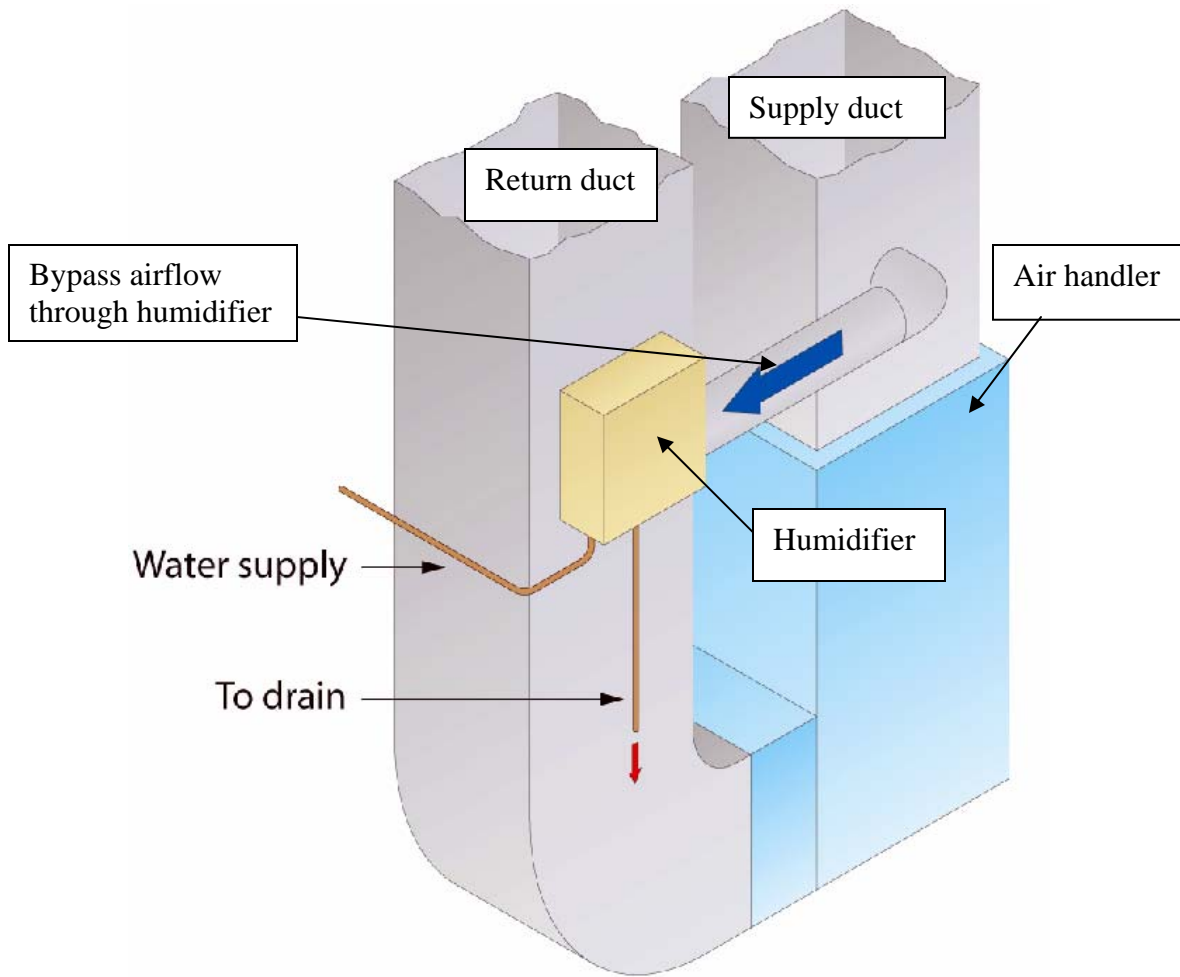

Fig. 1. Representative humidifier installation.

3.2 Centrally Ducted Air-Source Integrated Heat Pump (AS-IHP)

This concept, as shown in Figure 2, uses one variable-speed (VS) modulating compressor, two VS fans, one VS pump, and a total of four heat exchangers (HXs: two air-to-refrigerant, one water-to-refrigerant, and one air-to-water) to meet all the HVAC and water heating (WH) loads.

For the present analyses a humidifier, similar to that used in the baseline system was added to the IHP system. Initially the same water input as for the baseline case was used. But simulations using this flow rate showed water use more than double that of the baseline system. In an attempt to limit excessive water consumption we cut the water supply rate in half but this only reduced total water use by less than 10%. See the further discussion on water use in section 5.

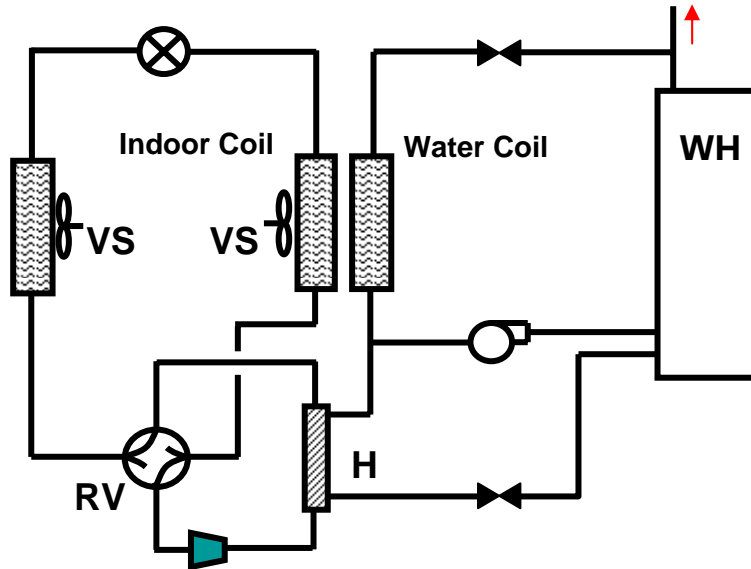

Fig. 2. Conceptual diagram of a central forced-air electric air-source integrated heat pump, showing operation in space-cooling mode.

3.3 Centrally Ducted Ground-Source Integrated Heat Pump (GS-IHP)

This technology is similar to the AS-IHP above but with the outdoor air coil and fan replaced with a refrigerant-to-water HX and secondary fluid pump connected to a conventional high-density polyethylene (HDPE) ground heat exchanger (HX), making a ground-coupled version of the IHP. As with other ground-source heat pumps the GS-IHP does not require a defrost cycle and with a properly sized ground HX operates with heat source and sink temperatures that are friendlier than outdoor air all year long. We plan to assess this option with both a vertical bore ground HX and a horizontal loop ground HX with SWS enhancement.

The humidifier used with the AS-IHP version was used in this case as well.

4. ANALYSIS APPROACH

The annual energy use simulations for the baseline and IHP HVAC systems were performed using the TRNSYS 16 platform (Solar Energy Laboratory, et al. 2006). Annual, hour-by-hour simulations were performed for both the baseline system and the IHPs prototype NZEH buildings for five locations - Atlanta, mixed-humid; Houston, hot-humid; Phoenix, hot-dry; San Francisco, marine; and Chicago; cold). The ORNL HPDM (Rice and Jackson 2002) was incorporated into the TRNSYS 16 model to enable sub-hourly simulation of the IHP performance.

5. SYSTEMS ENERGY CONSUMPTION RESULTS

Detailed results from the simulations for the NZEH (without humidifier) are given in Table 1. The total energy consumption and consumption by individual modes for the baseline system are from the hourly TRNSYS simulations. For the IHPs the total energy consumption, that of the ventilation fan, and for the electric backup water heating and space heating are from the detailed TRNSYS simulations as well. Breakdowns for the other modes for the IHPs were from the hourly simulations as well but with adjustments to fairly charge the water pump power in combined modes to the water heating function. Temperature control for the IHPs (average indoor temperature and magnitude and duration of extreme high and low periods) was equal or better than for the baseline in all cities. Cooling and shoulder season RH control by the IHP met the criteria of no more than 1-2% of hours with RH>60% everywhere but Houston as described in detail in the original report (Baxter 2006a).

Note that there are slight differences between the IHP performance as given in Table 1 above and in the two previous reports in this series - (from November, Table 7 (Baxter 2006a); and December, Table 4 (Baxter 2006b)). There are two principal reasons for these differences. First, for Atlanta it turns out that we inadvertently used a NZE house building file for the analyses behind the November and December results that was not fully consistent with the others. The error was not discovered until changes were being made to enable use of a humidifier for the present analyses. Changes to correct this oversight resulted in only a minor increase in both AS-IHP and GS-IHP energy use for Atlanta (<1%). Secondly, in late December a correction was made to the HPDM water-to-refrigerant evaporator pressure drop calculations. The revised version gives higher evaporator refrigerant-side pressure drops in space heating and winter water heating modes. As a result of this correction, the overall energy use for the GS-IHP in all cities increased modestly (by ~1-3% depending upon location) compared to the earlier results.

Table 1. IHP performance vs. baseline system in NZEH (no humidifier)
(reprinted from Baxter, 2006a; with corrections as noted in text)

| Loads (1800 ft ² NZEH from TRNSYS) | | Equipment | | | | |
|---|--------------|------------------------------------|------------------------------------|---------------------------------------|------------------------------------|---------------------------------------|
| | | Baseline | AS-IHP | | GS-IHP | |
| Source | kWh | Energy use, kWh (I ² r) | Energy use, kWh (I ² r) | Energy reduction compared to baseline | Energy use, kWh (I ² r) | Energy reduction compared to baseline |
| Atlanta | | | | | | |
| Space Heating | 4381 | 1597 | 1366 | 14.5% | 1107 | 30.7% |
| Space Cooling | 5770 | 2069 | 1242 | 40.0% | 1182 | 42.9% |
| Water Heating | 3032 | 3380 | 1105 (476) | 67.3% | 1211 (626) | 64.2% |
| Dedicated DH | 208 | 273 | 50 | 81.7% | 47 | 82.8% |
| Ventilation fan | - | 189 | 19 | 89.9% | 17 | 91.0% |
| Totals | 13391 | 7508 | 3782 | 49.6% | 3564 | 52.5% |
| Houston | | | | | | |
| Space Heating | 1700 | 616 | 540 | 12.3% | 407 | 33.9% |
| Space Cooling | 10093 | 3652 | 1810 | 50.4% | 1805 | 50.6% |
| Water Heating | 2505 | 2813 | 1028 (199) | 63.4% | 1029 (246) | 63.4% |
| Dedicated DH ¹ | 855 | 1059 | 620 | 41.4% | 604 | 43.0% |
| Ventilation fan | - | 189 | 13 | 93.1% | 12 | 93.7% |
| Totals | 15153 | 8329 | 4011 | 51.8% | 3853 | 53.7% |
| Phoenix | | | | | | |
| Space Heating | 1428 | 479 | 362 | 24.4% | 282 | 43.6% |
| Space Cooling | 9510 | 3985 | 2483 | 37.7% | 2267 | 43.1% |
| Water Heating | 2189 | 2470 | 689 (68) | 72.1% | 626 (66) | 74.7% |
| Dedicated DH | - | - | - | - | - | - |
| Ventilation fan | - | 189 | 33 | 82.5% | 33 | 82.5% |
| Totals | 13167 | 7123 | 3567 | 49.9% | 3208 | 55.0% |
| San Francisco | | | | | | |
| Space Heating | 2816 | 896 | 751 | 16.2% | 759 | 15.3% |
| Space Cooling | 86 | 32 | 26 | 18.8% | 23 | 28.0% |
| Water Heating | 3387 | 3766 | 1544 (749) | 59.0% | 1744 (1003) | 53.7% |
| Dedicated DH | 37 | 47 | 3 | 93.6% | 2 | 95.7% |
| Ventilation fan | - | 189 | 32 | 83.1% | 28 | 85.2% |
| Totals | 6326 | 4930 | 2356 | 52.2% | 2556 | 48.1% |
| Chicago | | | | | | |
| Space Heating | 10404 | 4678 (875) | 4000 (358) | 14.5% | 3524 (158) | 24.7% |
| Space Cooling | 2541 | 908 | 488 | 46.3% | 424 | 53.3% |
| Water Heating | 3807 | 4218 | 1544 (907) | 63.4% | 1823 (1166) | 56.8% |
| Dedicated DH | 127 | 162 | 60 | 63.0% | 51 | 68.5% |
| Ventilation fan | - | 189 | 16 | 91.5% | 14 | 92.6% |
| Totals | 16879 | 10155 | 6108 | 39.9% | 5836 | 42.5% |

¹ IHPs include additional energy consumption estimates to achieve ~same level of summer and shoulder season RH control as baseline in Houston – 411 kWh for AS-IHP; 408 kWh for GS-IHP.

Analyses results with the humidifier are given in Table 2. From comparison of results in Tables 1 and 2 several items can be noted. First energy use increased for all systems, baseline and IHPs. For the baseline systems there is some modest increase in water

heater energy use to cover the humidifier water usage. However the space heating energy use increased by a much greater amount in each city. For the IHPs, the water heating mode energy use increase was generally less than for the baseline system, reflecting the fact that the IHPs provided the additional hot water either at heat pumping efficiencies or as a by product of the added space heating and desuperheating operation. However, the space heating mode energy use for the IHPs (and consequently the total energy use) increased by a relatively greater amount compared to operation without a humidifier. The most likely reason for this greater relative increase is that the IHP humidifiers consumed more water than did those in the baseline case. This was despite the lower humidifier water use rate for the IHP. As noted earlier, the humidifiers modeled are passive bypass types that only can operate whenever the indoor blower is on. In the IHP case this involves many more hours during the heating season when indoor conditions would call for humidification. We initially chose to use simple, constant water input (0.5 gal/h) humidifiers for all systems in this analysis. For the baseline system almost all of the water input to the humidifier was evaporated into the air stream, whereas for the IHPs much of the water input ended up exiting through the humidifier drain line even when we cut the water input in half (especially so for locations with highest humidification needs, e.g., Chicago - ~60% of water drained). It may be that using a humidifier with variable water flow (rate tied to the indoor blower speed) for the IHPs would result in less overall water use and in overall energy savings vs. the baseline almost the same as for the “no humidifier” case. However, such a variable flow humidifier would also entail a larger capital cost. A water recirculation system may be another alternative to reduce water use in the IHP but this was judged to be beyond the scope of the current analysis. Further reduction of the water input rate could be examined as well to determine a value which would minimize water and energy use while still maintaining acceptable winter RH control.

Table 2. IHP performance vs. baseline system in NZEH (with humidifier)

| Loads (1800 ft ² NZEH from TRNSYS) | | Equipment | | | | |
|---|---------|------------------------------------|------------------------------------|---------------------------------------|------------------------------------|---------------------------------------|
| | | Baseline | AS IHP | | GS-IHP | |
| Source | kWh | Energy use, kWh (I ² r) | Energy use, kWh (I ² r) | Energy reduction compared to baseline | Energy use, kWh (I ² r) | Energy reduction compared to baseline |
| Atlanta | | | | | | |
| Space Heating | 4717 | 1724 (21) | 1597 | 7.4% | 1298 | 24.7% |
| Space Cooling | 5770 | 2069 | 1242 | 40.0% | 1182 | 42.9% |
| Water Heating | 3032 | 3402 | 1107 (492) | 67.5% | 1214 (645) | 64.3% |
| Dedicated DH | 208 | 273 | 50 | 81.7% | 47 | 82.8% |
| Ventilation fan | - | 189 | 18 | 90.5% | 16 | 91.5% |
| Totals | 13727 | 7657 | 4014 | 47.6% | 3757 | 50.9% |
| Δ% w/humidifier | 2.5% | 2.0% | 6.1% | | 5.4% | |
| Humidifier water use | 512 kg | 512 kg | 978 kg | | 907 kg | |
| Houston | | | | | | |
| Space Heating | 1734 | 626 | 576 | 8.0% | 433 | 30.8% |
| Space Cooling | 10093 | 3652 | 1810 | 50.4% | 1805 | 50.6% |
| Water Heating | 2505 | 2817 | 1033 (201) | 63.3% | 1031 (253) | 63.4% |
| Dedicated DH | 859 | 1065 | 620 | 41.8% | 604 | 43.0% |
| Ventilation fan | - | 189 | 13 | 92.6% | 12 | 93.7% |
| Totals | 15191 | 8349 | 4052 | 51.5% | 3885 | 53.5% |
| Δ% w/humidifier | 0.3% | 0.2% | 0.9% | | 0.8% | |
| Humidifier water use | 81 kg | 81 kg | 169 kg | | 147 kg | |
| Phoenix | | | | | | |
| Space Heating | 1546 | 515 | 414 | 19.6% | 316 | 38.6% |
| Space Cooling | 9510 | 3985 | 2483 | 37.7% | 2267 | 43.1% |
| Water Heating | 2189 | 2476 | 696 (86) | 71.9% | 649 (105) | 73.8% |
| Dedicated DH | - | - | - | - | - | - |
| Ventilation fan | - | 189 | 33 | 82.5% | 32 | 83.1% |
| Totals | 13285 | 7165 | 3626 | 49.4% | 3264 | 54.4% |
| Δ% w/humidifier | 0.9% | 0.6% | 1.7% | | 1.7% | |
| Humidifier water use | 167 kg | 167 kg | 340 kg | | 309 kg | |
| San Francisco | | | | | | |
| Space Heating | 2839 | 902 | 763 | 15.4% | 770 | 14.6% |
| Space Cooling | 86 | 32 | 26 | 18.8% | 23 | 28.0% |
| Water Heating | 3387 | 3767 | 1544 (749) | 59.0% | 1744 (1002) | 53.7% |
| Dedicated DH | 37 | 47 | 3 | 93.6% | 2 | 95.7% |
| Ventilation fan | - | 189 | 32 | 83.1% | 28 | 85.2% |
| Totals | 6349 | 4937 | 2368 | 52.0% | 2567 | 48.0% |
| Δ% w/humidifier | 0.4% | 0.1% | 0.6% | | 0.4% | |
| Humidifier water use | 32 kg | 32 kg | 96 kg | | 86 kg | |
| Chicago | | | | | | |
| Space Heating | 11259 | 5206 (1242) | 4863 (701) | 6.6% | 4270 (431) | 18.0% |
| Space Cooling | 2541 | 908 | 488 | 46.3% | 424 | 53.3% |
| Water Heating | 3807 | 4287 | 1511 (862) | 64.8% | 1815 (1137) | 57.7% |
| Dedicated DH | 127 | 162 | 60 | 63.0% | 51 | 68.5% |
| Ventilation fan | - | 189 | 16 | 91.5% | 14 | 92.6% |
| Totals | 17734 | 10752 | 6938 | 35.5% | 6574 | 38.9% |
| Δ% w/humidifier | 5.1% | 6.9% | 13.6% | | 12.6% | |
| Humidifier water use | 1387 kg | 1387 kg | 2713 kg | | 2683 kg | |

NOTE - Houston IHP DH mode energy use includes additional energy consumption estimates to achieve ~same level of summer and shoulder season RH control as baseline - 411 kWh for AS-IHP; 408 kWh for GS-IHP.

Space humidity control (winter and summer) performance was very good for both the baseline and IHP systems. Figures 3-6 illustrate space humidity levels over a year in Chicago for the three systems.

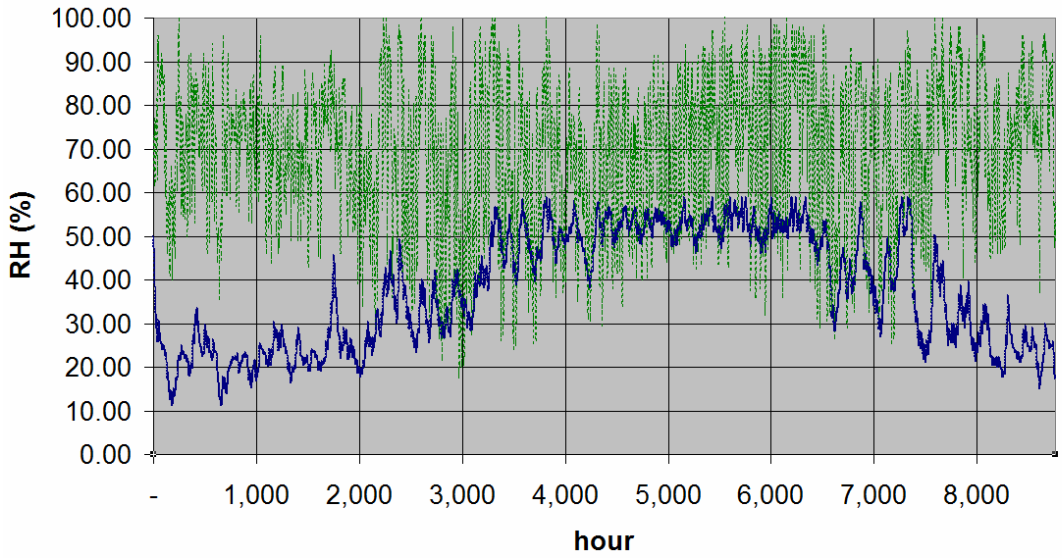

Fig. 3. Space and outdoor RH levels in Chicago for NZE house - baseline HVAC system, no humidifier.

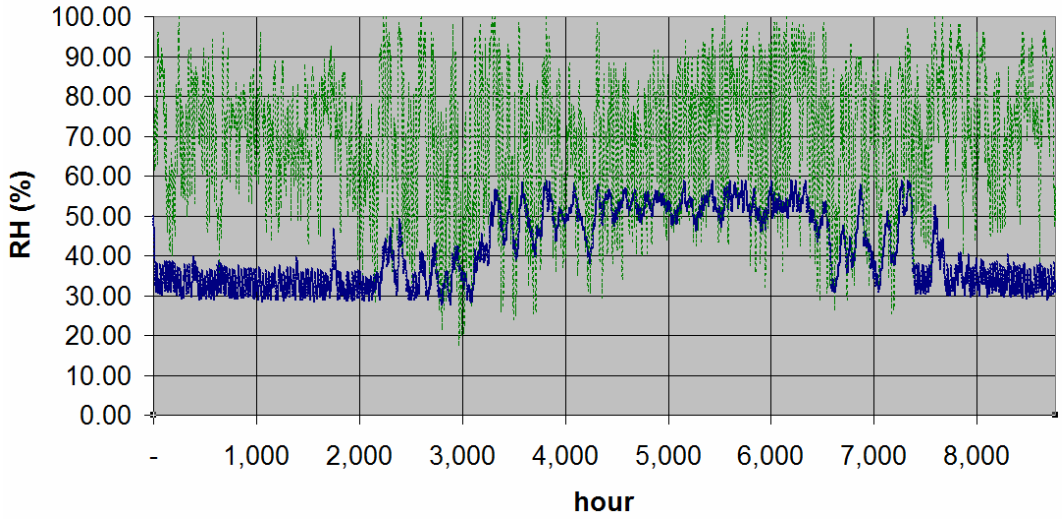

Fig. 4. Space and outdoor RH levels in Chicago for NZE house - baseline HVAC system with humidifier.

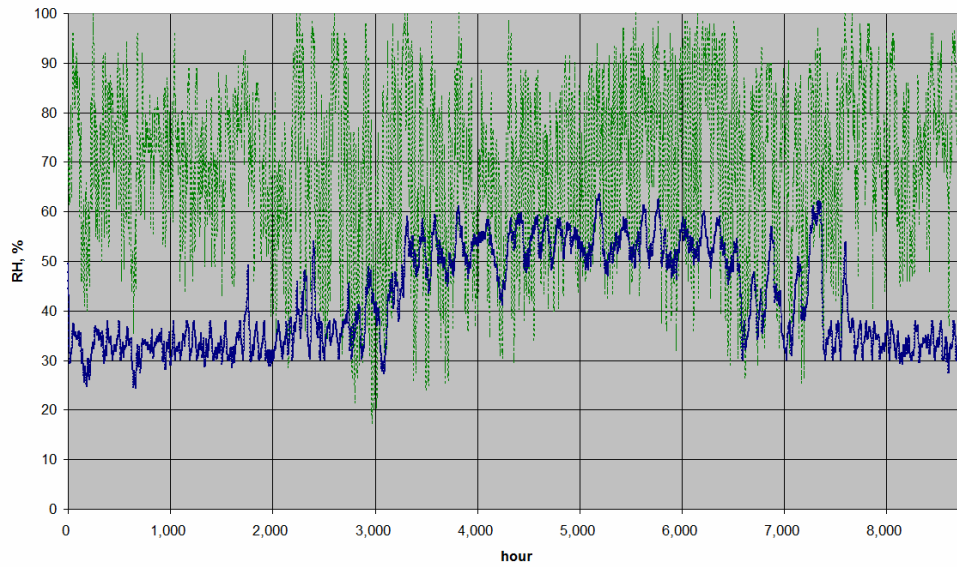

Fig. 5. Space and outdoor RH levels in Chicago for NZE house – AS-IHP with humidifier.

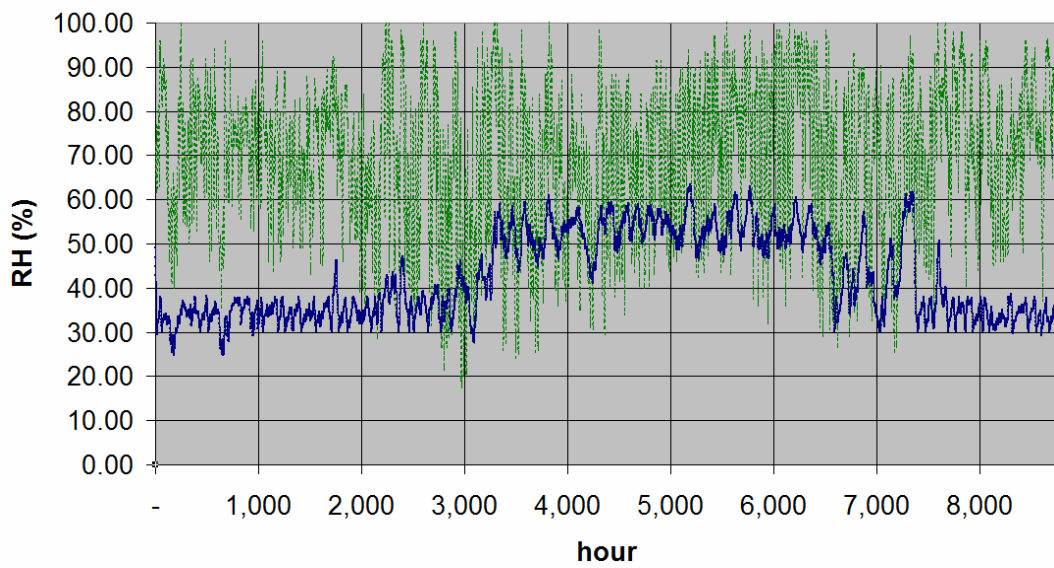

Fig. 6. Space and outdoor RH levels in Chicago for NZE house – GS-IHP with humidifier.

6. SYSTEM COST ESTIMATES and PAYBACK COMPARISONS

6.1 Differential System Cost due to Humidifier

Since we used essentially the same, relatively simple humidifier for both baseline and IHP systems, there is no differential impact on system installation costs in this case. The model corrections and higher water usage for the IHPs noted earlier did have some impact on the differential operating costs. Differential cost savings and paybacks for the IHP systems vs. the baseline with and without humidifier are discussed in the following sections. For water costs, internet searches were done to obtain current water costs for residential customers in each city. These costs are: \$0.0133/gal for Atlanta; \$0.00133/gal for Chicago; \$0.00268/gal in Houston; \$0.00184/gal in Phoenix (winter rate); and \$0.00263/gal in San Francisco. Electricity costs and cost savings for each city throughout this report were calculated based on 2006 electricity rates as implemented into BEopt (Spencer, 2006) - \$0.0872/kWh for Atlanta, \$0.0844/kWh for Chicago, \$0.108/kWh for Houston, \$0.0896/kWh for Phoenix, and \$0.1196/kWh for San Francisco.

Detailed cost estimates for the baseline HVAC/WH/DH system are given in Baxter (2006a). Table 3 gives the summary results from that document.

Table 3. Estimated installed costs for NZE house baseline HVAC/WH/DH system in 2006 dollars (from Baxter 2006a)

| City | Heat pump nominal cooling capacity (tons) | DH size (pts/d) | Heat pump cost | DH cost | WH cost | Vent fan cost | Total cost |
|---------------|---|-----------------|----------------|---------|---------|---------------|-------------|
| Atlanta | 1.25 | 40 | \$3985-4590 | \$415 | \$503 | \$305 | \$5208-5813 |
| Houston | 1.25 | 40 | \$3985-4590 | \$415 | \$503 | \$305 | \$5208-5813 |
| Phoenix | 1.50 | 40 | \$3995-4628 | \$415 | \$503 | \$305 | \$5218-5851 |
| San Francisco | 1.00 | 40 | \$3974-4578 | \$415 | \$503 | \$305 | \$5197-5801 |
| Chicago | 1.25 | 40 | \$3985-4590 | \$415 | \$503 | \$305 | \$5208-5813 |

6.2 AS-IHP

An artist's concept of the AS-IHP system is given in Figure 7. The basic heat pump system (compressor, indoor and outdoor coils, indoor blower, outdoor fan, refrigerant piping, flow controls, etc.) is similar to the baseline heat pump. While three separate sections (indoor air handler, outdoor coil, and compressor section) are shown in Figure 7, the system could conceivably be packaged in two sections like conventional split system heat pumps and air conditioners. To complete the IHP system, a water heater (with backup electric elements & controls), a refrigerant/water heat exchanger (for water heating), a multi-speed hot water circulation pump, connecting piping between the water

heater and heat pump, a water/air heat exchanger coil (for tempering heating during dehumidification operation), two water flow control valves (for tempering water flow and water heating operation), a return air damper, and a short duct with motorized damper for ventilation air are added to the basic heat pump.

Detailed cost estimates for the AS-IHP were developed by Baxter (2006a) and will not be repeated here. A summary of the system costs along with estimated payback vs. the baseline system is given in Table 4. The impact of the building file corrections discussed earlier on paybacks in Atlanta is very minor, ~0.1 year.

Table 4. Estimated installed costs for NZE house AS-IHP system without humidifier in 2006 dollars (from Baxter 2006a; with corrections)

| City | Heat pump capacity (tons) | Total cost | | Premium over baseline system | | Energy cost savings | Simple payback over baseline system, years | |
|---------------|---------------------------|------------|---------|------------------------------|---------|---------------------|--|------|
| | | low | high | Low | high | | low | High |
| Atlanta | 1.25 | \$7,745 | \$8,949 | \$2,537 | \$3,136 | \$325 | 7.8 | 9.7 |
| Houston | 1.25 | \$7,745 | \$8,949 | \$2,537 | \$3,136 | \$417 | 6.1 | 7.5 |
| Phoenix | 1.50 | \$7,759 | \$9,025 | \$2,541 | \$3,174 | \$319 | 8.0 | 10.0 |
| San Francisco | 1.00 | \$7,731 | \$8,925 | \$2,534 | \$3,124 | \$308 | 8.2 | 10.1 |
| Chicago | 1.25 | \$7,745 | \$8,949 | \$2,537 | \$3,136 | \$342 | 7.4 | 9.2 |

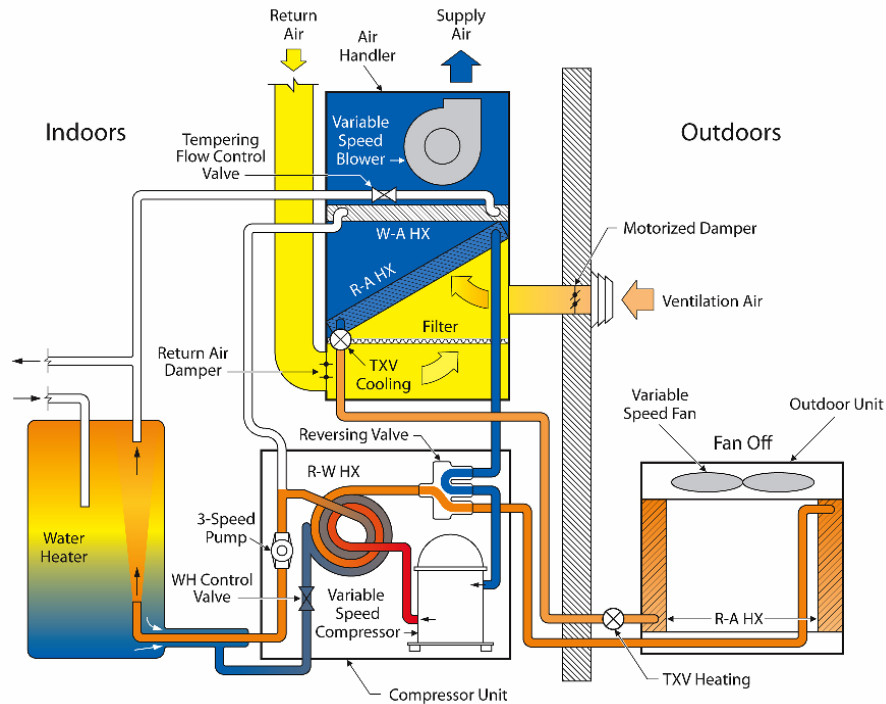

Fig. 7. Schematic of AS-IHP system, combined space cooling and demand water heating mode shown.

Estimated simple paybacks for the AS-IHP system vs. the baseline with a humidifier in Table 5 for each city. Net impacts on energy costs from adding a humidifier are negative (lower cost savings and longer paybacks in each city) but relatively minor. Paybacks

increased by ~½ year for Chicago (with greatest use of humidifier). In the other cities paybacks increased by 0.0-0.2 years. The impact of the added water use cost for the IHP is included in these numbers, however it is noted that this impact is negligible. IHP marginal water costs ranged from \$0.01 in Phoenix (minimal usage) to \$1.64 in Atlanta (moderately high usage and highest water rates).

Table 5. Estimated simple payback for NZE house AS-IHP system vs. baseline, both with humidifier (2006 dollars)

| City | Heat pump capacity (tons) | Premium over baseline system | | Energy cost savings | Simple payback over baseline system, years | |
|---------------|---------------------------|------------------------------|---------|---------------------|--|------|
| | | Low | High | | low | High |
| Atlanta | 1.25 | \$2,537 | \$3,136 | \$316 | 8.0 | 9.9 |
| Houston | 1.25 | \$2,537 | \$3,136 | \$413 | 6.1 | 7.6 |
| Phoenix | 1.50 | \$2,541 | \$3,174 | \$317 | 8.0 | 10.0 |
| San Francisco | 1.00 | \$2,534 | \$3,124 | \$307 | 8.2 | 10.2 |
| Chicago | 1.25 | \$2,537 | \$3,136 | \$321 | 7.9 | 9.8 |

6.3 GS-IHP

An artist’s concept for the GS-IHP system is shown in Figure 8. Detailed cost estimates for the GS-IHP were developed by Baxter (2006a) and will not be repeated here.

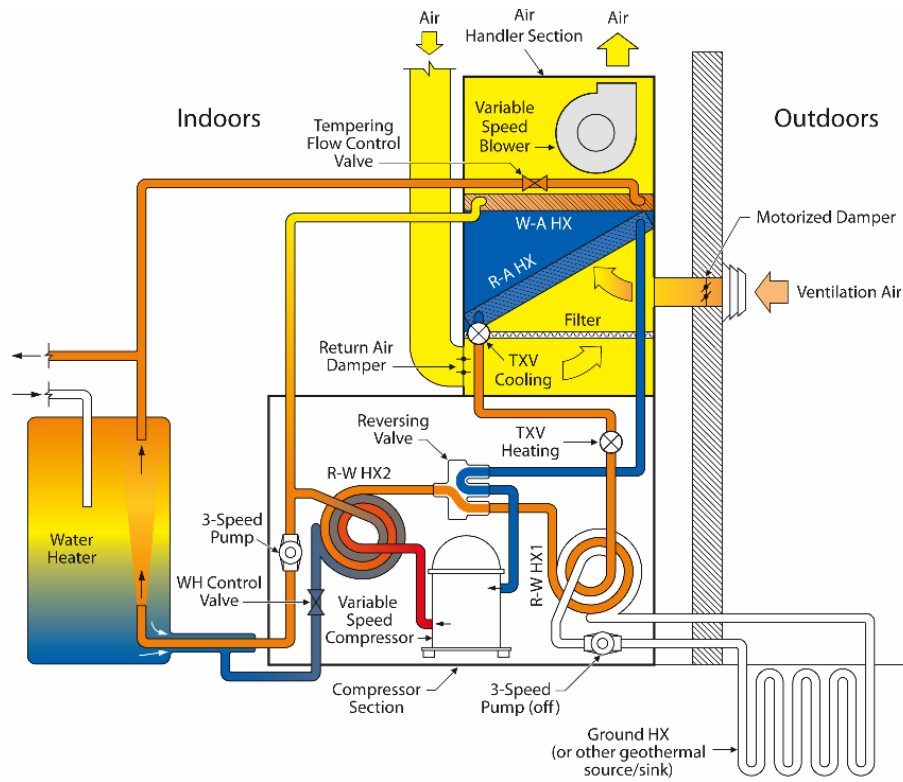

Fig. 8. Schematic of GS-IHP system, dedicated dehumidification mode shown.

A summary of the system costs along with estimated payback vs. the baseline system is given in Table 6. The impact of the HPDM water-to-refrigerant evaporator code corrections on the GS-IHP paybacks is relatively minor, ~0.3-0.4 year increase in Chicago and Atlanta, 0.2 year or less in all other cities.

Table 6. Estimated installed costs for NZE house GS-IHP system in 2006 dollars – assuming vertical bore ground HX at \$1000/ton installed (from Baxter 2006a; with corrections)

| City | Heat pump capacity (tons) | Total cost | | Premium over baseline system | | Energy cost savings | Simple payback over baseline system, years | |
|---------------|---------------------------|------------|---------|------------------------------|---------|---------------------|--|------|
| | | Low | high | low | high | | low | High |
| Atlanta | 1.25 | \$8,280 | \$9,369 | \$3,072 | \$3,556 | \$344 | 8.9 | 10.3 |
| Houston | 1.25 | \$8,280 | \$9,369 | \$3,072 | \$3,556 | \$433 | 7.1 | 8.2 |
| Phoenix | 1.50 | \$8,548 | \$9,687 | \$3,330 | \$3,836 | \$351 | 9.5 | 10.9 |
| San Francisco | 1.00 | \$8,010 | \$9,097 | \$2,813 | \$3,296 | \$284 | 9.9 | 11.6 |
| Chicago | 1.25 | \$8,280 | \$9,369 | \$3,072 | \$3,556 | \$365 | 8.4 | 9.8 |

Estimated installed costs and simple paybacks for the humidifier case are given in Table 7 for Houston and Phoenix. Humidifier impact on system paybacks ranged from about a 1 year increase in Atlanta to <0.3 year increase in other cities.

Table 7. Estimated simple payback for NZE house GS-IHP system vs. baseline, both with humidifier (2006 dollars)

| City | Heat pump capacity (tons) | Premium over baseline system | | Energy cost savings | Simple payback over baseline system, years | |
|---------------|---------------------------|------------------------------|---------|---------------------|--|------|
| | | low | high | | Low | High |
| Atlanta | 1.25 | \$3,072 | \$3,556 | \$316 | 9.7 | 11.2 |
| Houston | 1.25 | \$3,072 | \$3,556 | \$431 | 7.1 | 8.2 |
| Phoenix | 1.50 | \$3,330 | \$3,836 | \$350 | 9.5 | 11.0 |
| San Francisco | 1.00 | \$2,813 | \$3,296 | \$283 | 9.9 | 11.6 |
| Chicago | 1.25 | \$3,072 | \$3,556 | \$352 | 8.7 | 10.1 |

6.4 GS-IHP/SWS

The solid-water-sorbent- (SWS) enhanced environmental coupling concept (Ally 2006) is being investigated for its potential to reduce the size (and cost) of the ground HX required for the GS-IHP. Details on the estimation of cost for a GS-IHP with SWS-enhanced ground heat exchanger are given in Baxter (2006a). A summary of the system costs and simple paybacks for the GS-IHP/SWS system are given in Table 8. The impact of the code corrections on paybacks for this system is similar to that for the GS-IHP.

Table 8. Estimated installed costs for NZE house SWS-enhanced GS-IHP system in 2006 dollars (from Baxter 2006a; with corrections)

| City | Heat pump capacity (tons) | Total cost | | Premium over baseline system | | Energy cost savings | Simple payback over baseline system, years | |
|---------------|---------------------------|------------|---------|------------------------------|---------|---------------------|--|------|
| | | Low | High | low | high | | low | high |
| Atlanta | 1.25 | \$7,718 | \$8,807 | \$2,510 | \$2,994 | \$344 | 7.3 | 8.7 |
| Houston | 1.25 | \$7,718 | \$8,807 | \$2,510 | \$2,994 | \$433 | 5.8 | 6.9 |
| Phoenix | 1.50 | \$7,878 | \$9,017 | \$2,660 | \$3,166 | \$351 | 7.6 | 9.0 |
| San Francisco | 1.00 | \$7,558 | \$8,645 | \$2,361 | \$2,844 | \$284 | 8.3 | 10.0 |
| Chicago | 1.25 | \$7,718 | \$8,807 | \$2,510 | \$2,994 | \$365 | 6.9 | 8.2 |

Estimated installed costs and simple paybacks for the humidifier-equipped SWS/GS-IHP system are given in Table 9 for Houston and Phoenix. Humidifier impact on system paybacks ranged from ~0.7 year increase in Atlanta to <0.3 year increase in other cities.

Table 9. Estimated simple payback for NZE house GS-IHP/SWS system vs. baseline, both with humidifier (2006 dollars)

| City | Heat pump capacity (tons) | Premium over baseline system | | Energy cost savings | Simple payback over baseline system, years | |
|---------------|---------------------------|------------------------------|---------|---------------------|--|------|
| | | low | high | | Low | high |
| Atlanta | 1.25 | \$2,510 | \$2,994 | \$316 | 7.9 | 9.5 |
| Houston | 1.25 | \$2,510 | \$2,994 | \$431 | 5.8 | 6.9 |
| Phoenix | 1.50 | \$2,660 | \$3,166 | \$350 | 7.6 | 9.1 |
| San Francisco | 1.00 | \$2,361 | \$2,844 | \$283 | 8.3 | 10.0 |
| Chicago | 1.25 | \$2,510 | \$2,994 | \$352 | 7.1 | 8.5 |

7. CONCLUSIONS

A simple, bypass-type whole-house humidifier model was incorporated into the baseline HVAC system and the AS- and GS-IHP systems and analyzed on an hourly basis for five locations in the US. The principal observations gleaned from the analyses summarized in this report are as follow.

- Both the baseline and IHP systems provide acceptable levels of indoor RH control in summer and winter.
- Adding the humidifier resulted in increased energy consumption for all systems. Most of the increase was due to increased space heating mode operation to overcome the cooling effect of the evaporated water on the indoor supply air stream.
- Energy consumption for the IHPs increased more than did that of the baseline system probably because the IHP humidifiers also consumed more water. As noted, the humidifiers modeled are passive bypass types that only can operate whenever the indoor blower is on, and consume water at a constant rate – 0.5

- gal/h for the baseline and 0.25 gal/h for the IHPs. Despite a lower water rate, the far greater number of space heating operating hours in the IHP cases resulted in greater use of hot water – much of which went out the humidifier drain. Using a humidifier with variable water flow for the IHPs may have resulted in less overall water and energy use and still provide similar winter RH control. However, such a variable flow humidifier would also entail a larger capital cost with negative impacts on simple payback – perhaps greater than that caused by the extra energy used to overcome the excessive water use as reported above.
- The IHP energy savings vs. the baseline system decreased slightly (by up to four percentage points in the worst case, Chicago). However, simple paybacks increased only marginally, less than 0.3 years in most cases.

One general note – the simulation results summarized in this report (Tables 1 and 2) show that the GS-IHP outperforms the AS-IHP in four of the five locations studied. The performance spread is not large, ~2-5% greater savings vs. the baseline system. However, the ground-source design is not as far along in its development process and consequently not as well optimized as the air-source at this point. Therefore it is likely that the GS-IHP performance results are somewhat more conservative than those of the AS-IHP.

REFERENCES

- Ally, M. R. (2006). Data and Analyses of SWS performance in Field Experiments for Interim DOE Go/No-Go Decision: Oak Ridge National Laboratory, June 30 DRAFT.
- Anderson, R.; C. Christensen, G. Barker, S. Horowitz, A. Courtney, T. Givler, K. Tupper, (2004). Analysis of System Strategies Targeting Near-Term Building America Energy-Performance Goals for New Single-Family Homes: FY 2004 Fourth-Quarter Building America Milestone Report. 55 pp.; NREL/TP-550-36920.
- ASHRAE (2004). ANSI/ASHRAE Standard 62.2-2004: Ventilation and Acceptable Indoor Air Quality in Low-Rise Residential Buildings.
- ASHRAE (2005). 2005 ASHRAE Handbook, Fundamentals.
- Baxter, V. (2005). HVAC Equipment Design Options for Near-Zero-Energy Homes – A Stage 2 Scoping Assessment. ORNL/TM-2005/194. November.
- Baxter, V. (2006a). Initial Business Case Analysis of Two Integrated Heat Pump HVAC Systems for Near-Zero-Energy Homes, ORNL/TM-2006/130, November.
- Baxter, V. (2006b). Initial Business Case Analysis of Two Integrated Heat Pump HVAC Systems for Near-Zero-Energy Homes – Update to Include Analyses of an Economizer Option and Alternative Winter Water Heating Control Option, ORNL/TM-2006/625, December.
- Christensen, C. (2005). NREL, e-mail communication with C.K. Rice of ORNL, July 2005.

DOE/BT (2005). Building Technologies Program Research, Development, Regulatory, and Market Introduction Plan – Planned Program Activities for 2006-2011. Revised Second Generation Draft, August 1.

EHD (1987). Exposure guidelines for residential indoor air quality. EHD-TR-156. Environmental Health Directorate, Health Protection Branch. Ottawa, ON

Harriman, L. G.; G. W. Brundrett; and R. Kittler (2001). Humidity Control Design Guide for Commercial and Institutional Buildings. ASHRAE Research Project 1047-RP final report.

Rice, C. K and W. L. Jackson (2002). DOE/ORNL Heat Pump Design Model On the Web, Mark VI Version October. <http://www.ornl.gov/~wlj/hpdm/MarkVI.html>.

Solar Energy Laboratory (Univ of WI), TRANSSOLAR Energietechnik, CSTB – Centre Scientifique et Technique du Bâtiment, and TESS – Thermal Energy System Specialists, 2006. TRNSYS 16: a TRAnsient SYstem Simulation program, Version 16.01.0000.

Spencer, J. (2006). Personal communication from Justin Spencer, NREL, to Van D. Baxter, September.