

**Use of Activated Charcoal for ^{220}Rn
Adsorption for Operations Associated
with the Uranium Deposit in the
Auxiliary Charcoal Bed at the Molten
Salt Reactor Experiment Facility**

R. L. Coleman

This report has been reproduced directly from the best available copy.

Available to DOE and DOE contractors from the Office of Scientific and Technical Information, P.O. Box 62, Oak Ridge, TN 37831; prices available from 423-576-8401.

Available to the public from the National Technical Information Service, U.S. Department of Commerce, 5285 Port Royal Rd., Springfield, VA 22161.

This report was prepared as an account of work sponsored by an agency of the United States Government. Neither the United States Government nor any agency thereof, nor any of their employees, makes any warranty, express or implied, or assumes any legal liability or responsibility for the accuracy, completeness, or usefulness of any information, apparatus, product, or process disclosed, or represents that its use would not infringe privately owned rights. Reference herein to any specific commercial product, process, or service by trade name, trademark, manufacturer, or otherwise, does not necessarily constitute or imply its endorsement, recommendation, or favoring by the United States Government or any agency thereof. The views and opinions of authors expressed herein do not necessarily state or reflect those of the United States Government or any agency thereof.

LIFE SCIENCES DIVISION

**Use of Activated Charcoal for ^{220}Rn Adsorption for Operations
Associated with the Uranium Deposit in the Auxiliary Charcoal
Bed at the Molten Salt Reactor Experiment Facility**

R. L. Coleman

Date Issued—March 1999

Prepared for the MSRE Remediation Project,
Bechtel Jacobs Company LLC
Oak Ridge, Tennessee 37831
under contract DE-AC05-98OR22700

Prepared by the
OAK RIDGE NATIONAL LABORATORY
Oak Ridge, Tennessee 37831-6285
managed by
LOCKHEED MARTIN ENERGY RESEARCH CORP.
for the
U.S. DEPARTMENT OF ENERGY
under contract DE-AC05-96OR22464

Author Affiliation

R. L. Coleman is a member of the Measurement Applications and Development Group, Assessment Technology Section, Life Sciences Division, Oak Ridge National Laboratory, Lockheed Martin Energy Research Corp., Oak Ridge, Tennessee.

CONTENTS

FIGURES	v
TABLES	vii
ACKNOWLEDGMENTS	ix
ABSTRACT	xi
1. INTRODUCTION	1
2. BACKGROUND	2
3. MEASUREMENT METHODS	4
3.1 MATERIALS AND EQUIPMENT	4
3.2 LOW CONCENTRATION MEASUREMENTS	4
3.3 HIGH CONCENTRATION MEASUREMENTS	5
4. MEASUREMENT RESULTS	6
4.1 LOW CONCENTRATION MEASUREMENTS	6
4.2 HIGH CONCENTRATION MEASUREMENTS	6
4.3 RADON AVAILABILITY IN THE URANIUM DEPOSIT	7
4.4 FISSION GAS AVAILABILITY IN THE URANIUM DEPOSIT	8
4.5 MEASUREMENT UNCERTAINTIES	8
5. PROPOSED CHARCOAL FILTER DESIGN	10
5.1 FILTRATION EFFECTIVENESS	10
5.2 FILTER CAPACITY	11
5.3 EFFECT OF TEMPERATURE, HUMIDITY, AND OTHER GASES	12
5.4 POTENTIAL HAZARDS	13
6. SUMMARY	14
7. REFERENCES	15

FIGURES

1	Decay chain for ^{232}U	16
2	Design schematic of the charcoal cartridge used when sampling ^{220}Rn from the uranium deposit in the charcoal bed at the MSRE	17
3	Simplified schematic of flow diagram for testing of radon adsorption from the uranium deposit in the auxiliary charcoal bed at the MSRE	18
4	Results for ^{220}Rn adsorption tests at low input concentrations with velocities of 18 and 24 cm s^{-1} (35 and 47 ft min^{-1})	19
5	Results for ^{220}Rn adsorption tests at low input concentrations with velocities of 10 and 33 cm s^{-1} (20 and 65 ft min^{-1})	20
6	Results for ^{220}Rn adsorption tests at (A) a low input concentration with a velocity of 18 cm s^{-1} (35 ft min^{-1}) and (B) a high input concentration with a velocity of 20 cm s^{-1} (40 ft min^{-1})	21
7	Schematic of proposed charcoal filter to be used during uranium deposit removal from the auxiliary charcoal bed at the MSRE	22
8	Plot of measured TVL values versus flow velocity	23

TABLES

1	Gamma spectrometry analysis results for charcoal adsorption tests at the MSRE	24
2	Summary of measured tenth-value layers (TVL) for ^{220}Rn passing through activated charcoal.	25

ACKNOWLEDGMENTS

The author wishes to acknowledge support, assistance, and comments provided by R. A. Campbell, R. L. Faulkner, M. H. Haghghi, F. J. Peretz, J. M. Rushton, R. M. Szozda, L. D. Trowbridge, and J. L. Westbrook of the MSRE project. The author also acknowledges valuable technical assistance from M. E. Murray, editorial assistance from M. S. Uziel, and field measurement support by V. P. Patania and D. A. Roberts—all of the Life Sciences Division.

ABSTRACT

Measurements have been collected with the purpose of evaluating the effectiveness of activated charcoal for the removal of ^{220}Rn from process off-gas at the Molten Salt Reactor Experiment (MSRE) at Oak Ridge National Laboratory. A series of bench-scale tests were performed at superficial flow velocities of 10, 18, 24, and 33 cm s^{-1} (20, 35, 47, and 65 ft min^{-1}) with a continuous input concentration of ^{220}Rn in the range of $9 \times 10^3 \text{ pCi L}^{-1}$. In addition, two tests were performed at the MSRE facility by flowing helium through the auxiliary charcoal bed uranium deposit. These tests were performed so that the adsorptive effectiveness could be evaluated with a relatively high concentration of ^{220}Rn . In addition to measuring the effectiveness of activated charcoal as a ^{220}Rn adsorption media, the source term for available ^{220}Rn and gaseous fission products was evaluated and compared to what is believed to be present in the deposit. The results indicate that only a few percent of the total ^{220}Rn in the deposit is actually available for removal and that the relative activity of fission gases is very small when compared to ^{220}Rn . The measurement data were then used to evaluate the expected effectiveness of a proposed charcoal adsorption bed consisting of a right circular cylinder having a diameter of 43 cm and a length of 91 cm (17 in. I.D. \times 3 ft.). The majority of the measurement data predicts an overall ^{220}Rn activity reduction factor of about 1×10^9 for such a design; however, two measurements collected at a flow velocity of 18 cm s^{-1} (35 ft min^{-1}) indicated that the reduction factor could be as low as 1×10^6 . The adsorptive capacity of the proposed trap was also evaluated to determine the expected life prior to degradation of performance. Taking a conservative vantage point during analysis, it was estimated that the adsorption effectiveness should not begin to deteriorate until a ^{220}Rn activity on the order of 10^{10} Ci has been processed. It was therefore concluded that degradation of performance would most likely occur as the result of causes other than filling by radon progeny.

1. INTRODUCTION

Planned remediation at the Oak Ridge National Laboratory (ORNL) Molten Salt Reactor Experiment (MSRE) facility created the need to trap ^{220}Rn from process off-gas. Methods for removal of the inert gas were evaluated and it was decided that adsorption by activated charcoal should be considered. An initial literature review did not return direct matches of analytical data related to the anticipated use; therefore, it was decided that measurements would be collected.

A hazard associated with ^{233}U material is the production of ^{220}Rn from the ^{232}U decay chain. Although ^{232}U is in ^{233}U material at a small mass fraction, it can equate to a significant activity level due to its short half-life. A summary of the ^{232}U decay series is presented in Fig. 1 (p. 16) for easy reference and shows the path by which ^{220}Rn is produced. Radon will be in secular equilibrium with ^{228}Th , which in turn will reach secular equilibrium with ^{232}U within 13 years of original uranium purification. To illustrate the magnitudes of activity expected, consider the fuel material in the auxiliary charcoal bed at the MSRE facility, which supposedly contains ^{232}U at a mass concentration of 160 ppm.¹ After a period of about 13 years the ^{228}Th activity would have equilibrated to about 3.5 Ci kg^{-1} of uranium. A kilogram of uranium would therefore be expected to produce ^{220}Rn at a rate of $1.3 \times 10^{11} \text{ atoms s}^{-1}$, or $4.4 \times 10^{-2} \text{ Ci s}^{-1}$, after ^{228}Th became equilibrated.

Experiments were initiated with the goal of creating a data set that directly represented the adsorptive ability of activated charcoal at the flow rates and radon concentrations of interest. The purpose of this report is to

- summarize the results of both low and high activity experiments performed to measure the adsorption of ^{220}Rn onto activated charcoal, and
- evaluate the proposed radon filtration design to be used during the uranium deposit removal (UDR) from the auxiliary charcoal bed at the MSRE.

¹ The mass concentration of ^{232}U and ^{233}U in the uranium deposit within the auxiliary charcoal bed at the MSRE is assumed based on personal conversations with representatives working on decontamination efforts at the facility and is considered to be a *best estimate*.

2. BACKGROUND

A brief overview of general concepts describing adsorptive materials and processes serves as an informative introduction for this study. Activated charcoal is manufactured by heating carbon materials, such as nut shells and wood, to 800°C to 900°C in an oxygen deficient atmosphere that includes steam or carbon dioxide (Hawley 1977). The charcoal contains an intricate matrix of pore volumes with a wide range of sizes. The pores can generally be classified as large, intermediate, and micro (Dubinin 1972), with micro-pores having measured effective radii in the range of 5 to 10 Å. The internal surface area of the pore space typically averages about 900 m² g⁻¹ and the bulk density is typically less than 0.5 g cm⁻³ (Hawley 1977). The process of adsorption involves a complex mix of physical interactions within all size ranges of pore volumes and interstitial spaces.

From a practical vantage point, an adsorbent bed is best described as a retention system, where the rate of movement of adsorbates within a liquid or gas carrier is retarded between the entry and exit of the carrier gas or liquid. The process can also be compared to condensation, in that molecules retained within the pore spaces are relatively immobile and therefore exist in a separate phase. Adsorbed, inert molecules can eventually emerge, or desorb, and be free to move again—which is similar in concept to evaporation. The probability of adsorption decreases with temperature and increases with pressure, also a corollary to gas and liquid phase changes. Desiccants are a good example of a common adsorbent. Water is retained with a very high probability within the porous matrix and has a relatively low desorption probability under standard environmental conditions. When heated, of course, the energy level of the adsorbed molecules is raised with subsequent escape, or desorption, becoming highly probable.

When an adsorbate is a radioactive species, such as radon, a secondary but very important process occurs. Since an adsorbent bed can act as a complicated delay system, then this will necessarily equate to an increased probability of radioactive decay of atoms prior to exiting the bed. Once a decay occurs, the resulting daughter will not likely move since it will be both charged and chemically reactive. Therefore, with each decay, the pore volume available for future adsorption is effectively decreased.

A literature search for filtration of radon by charcoal from air streams was performed and two papers were found that appeared to be directly applicable. The first focused on a fundamental derivation of equations describing the removal of ²²²Rn from air streams (Blue et al. 1995), while the second focused on the removal of ²²⁰Rn (Ackley 1975). Neither paper contained measurement data of radon filtration from a moving gas stream. The work by Blue built on work by many others with the intention of formulating a mathematical model that would predict the adsorptive ability of charcoal while accurately accounting for the effects of water molecules in air. This work specifically focused on ²²²Rn; however, the model is presented with ample detail such that modification appeared to be possible for application to ²²⁰Rn. It also should be noted that many papers were found related to the adsorption of ²²²Rn onto charcoal, but the information was typically not directly applicable for determining

removal efficiencies from moving gas streams. In fact, the majority of work in this area has focused on charcoal sampling of radon from indoor air by passive diffusion devices.

Of particular interest at the MSRE was the removal of ^{220}Rn from gas streams moving at a relatively high velocity; therefore, the analysis given by Ackley was considered to be directly applicable. Ackley presented the application of gas chromatography mechanics from publications by others to describe the holdup and decay of radioactive noble gases on activated charcoal. The result of this approach was an equation set that allowed the prediction of radon removal in an air stream using a combination of known and estimated parameters.

Factors that affect radon adsorption from a flowing stream of gas onto charcoal include (a) the properties of the charcoal used such as granularity, material type, and porosity; (b) the concentration of water or other competing molecules in the gas; (c) the rate of movement of the gas through the charcoal; and (d) the half-life of the radon isotope being evaluated. The number of *radon-affinitive* adsorber sites in activated charcoal is expected to be extremely large, with available estimates placing this value on the order of 10^{21} cm^{-3} (Blue et al. 1995). The collective term *adsorber sites* is used here to describe the overall adsorptive capacity of charcoal for radon and is empirically related to the number of atoms, including decay products, that could be retained within a fixed volume of charcoal under saturation conditions. Given such a large number of supposedly available sites and the high specific activity of ^{220}Rn , the effect of input concentration on adsorption capability should be small over a very broad range of concentrations. Since no data were available to demonstrate that this assumption was true, it was decided that tests would include measurements at high input concentrations to represent actual use conditions appropriately.

Given a specific adsorption bed and gas composition, the dominant variable that was expected to control ^{220}Rn removal effectiveness was the linear flow velocity since the model by Blue indicated this to be an important factor. To characterize the adsorption ability, it was therefore deemed important to collect data across the range of velocities expected during actual operation. A second variable of interest was the effect of input concentration on the effectiveness of adsorption. Theory predicted that the adsorptive ability of charcoal for ^{220}Rn would be relatively insensitive to input concentration; however, measurements were performed to validate this belief.

3. MEASUREMENT METHODS

A series of measurements were performed at a relatively low input radon concentration during bench-scale tests at superficial flow velocities of 10, 18, 24, and 33 cm s⁻¹ (20, 35, 47, and 65 ft min⁻¹). In addition, two sets of data were collected at 11 and 20 cm s⁻¹ (22 and 40 ft min⁻¹) with a high input concentration by flowing gas through the uranium deposit in the MSRE auxiliary charcoal bed. As used in this report, the flow velocity is calculated by dividing the cross-sectional area of the sample cartridge being used by the actual volumetric flow rate in the cartridge. Therefore, unless otherwise noted, volumetric rates and superficial velocities are given at the presiding density and flow in the sampling tube (i.e., density conversions to standard conditions have not been performed).

3.1 MATERIALS AND EQUIPMENT

The charcoal used for these tests was Calgon Carbon PCB-6×16. The activated charcoal was coconut-based with a 6 × 16 mesh sizing and the bulk density was measured to be 0.41 g cm⁻³. All samples were analyzed using a high purity germanium (HPGe) gamma spectrometry system following standard guidelines published in ORNL/TM-6782 (ORNL 1995). For these samples, ²¹²Pb was used as the major analysis marker for ²²⁰Rn, and all results were decay-corrected to the time at which the sample was collected.

3.2 LOW CONCENTRATION MEASUREMENTS

Bench-scale tests were performed by flowing room air with a continuous ²²⁰Rn concentration of about 9000 pCi L⁻¹ through a ~4.8-cm-diameter column of charcoal at flow velocities of 10, 18, 18, 24, and 33 cm s⁻¹, which correspond to volumetric rates through the sample cartridge of approximately 10, 20, 20, 25, and 36 L min⁻¹, respectively. Note that a second sample was collected at a flow velocity of 18 cm s⁻¹ (35 ft min⁻¹) in order to confirm the result of the first. Each sample was collected overnight allowing more than an adequate amount of time to establish a steady state radon adsorption, desorption, and decay condition. In fact, it would take less than 10 min for this condition to be reached since the rate of equilibrium formation would be controlled by the 55-s half-life of ²²⁰Rn. Flow rates for the samples were measured using a wet-test meter, which is an absolute displacement type of device. Pressure drops across the sample housing were measured for all measurements and were confirmed to be very small, with typical values observed being about 1 cm of water. The samples are referenced as numbers 7710CT001 through 7710CT005. Measurements of room temperature and relative humidity were not performed for each measurement; however, typical values for the facility during the period would have been about 20°C and 40 to 60%, respectively.

3.3 HIGH CONCENTRATION MEASUREMENTS

Parameters provided in the literature, as well as what was determined in the low-concentration measurement tests, were based on radon interactions with charcoal at relatively low concentrations. For example, the bench-scale-tests conducted during the present study were performed at an estimated ^{220}Rn concentration of $\sim 9000 \text{ pCi L}^{-1}$, and the physical parameters referenced in the literature were typically determined with ^{222}Rn at similar or lower concentrations. To confirm that a high concentration would not affect adsorptive ability, it was decided that at least one test should be performed with the same order of activity that would be expected during operation of a filter when used during remedial tasks at the MSRE. The auxiliary charcoal bed uranium deposit at the MSRE was chosen as a source for testing with a high concentration of ^{220}Rn . Based on conversations with facility personnel, the deposit was estimated to have an equilibrated ^{228}Th activity of 6 to 9 Ci, with the equilibrated activity of ^{220}Rn being the same. Assuming a 9 Ci ^{228}Th activity, ^{220}Rn would be produced in the deposit at a rate of $3.3 \times 10^{11} \text{ s}^{-1}$, which equates to an expected continuous ^{220}Rn production rate of 0.11 Ci s^{-1} . Considering its 55-s half-life, ^{220}Rn would equilibrate with ^{228}Th within 10 min assuming removal was not occurring by any other means.

A sample cartridge was constructed of 4.8-cm inside diameter (ID) PVC schedule 80 piping and filled with approximately 1 kg of charcoal. A schematic of the cartridge is given in Fig. 2 (p. 17). The first test was performed with a total of 9 sample sections having a nominal mass of about 120 g each and was referenced as sample number MSRECT001. The experiments were performed by first purging the deposit with helium for a 5-min period so that a static equilibrium concentration in the sample line would be established. The gas was then diverted into the charcoal trap and allowed to flow for a period of 10 min. The first test was performed at a linear flow rate through the charcoal trap of 11 cm s^{-1} (22 ft min^{-1}), which corresponded to a volumetric rate of 12 L min^{-1} . A simplified schematic of the flow system used is shown in Fig. 3 (p. 18). The flow rate was measured using a rotameter calibrated to air at standard temperature and pressure and then corrected for actual specific gravity and density.

The second test, referenced as MSRECT002, was performed using the same sample cartridge, except that a different test arrangement was used to avoid mistakes observed during the first trial. The input segment was further divided into seven layers of $\sim 35 \text{ g}$ each and the segment following it was divided into two 55-g layers. The remaining segments of MSRECT002 had a nominal mass of about 120 g each. The linear flow rate through the cartridge for this test was 20 cm s^{-1} (40 ft min^{-1}), which corresponded to a volumetric rate of 22 L min^{-1} . The measurement sequence was also altered to allow better sensitivity for adsorbed activity in the lower sections of the cartridge. Note that the velocity was increased during the second test by modification of the pumping arrangement and was the maximum that could be achieved using the available MSRE vacuum pump.

4. MEASUREMENT RESULTS

4.1 LOW CONCENTRATION MEASUREMENTS

Each sample column was broken into approximately 1.8-cm-thick layers, analyzed for total ^{212}Pb , and then decay corrected to the time of sample collection. The total activity input to each column, A_T , was estimated by summing the measured activity across all layers. In addition, the residual activity, R_i , remaining after passing through a layer was calculated by summing the activity in the layers following it. Each residual was then divided by the total activity (i.e., R_i/A_T) and plotted as a function of depth as shown in Figs. 4 through 6 (pp. 19–21). The result for the first sample layer for each set of data was discarded and a logarithmic fit was performed for the remaining points. The general observation, with the exception of sample 7710CT001, was that >99% of the activity entering the column was retained within the charcoal cartridge. Sample 7710CT001 showed a total radon retention of about 97%.

The measurement result for the first layer of each sample was discarded due to the geometry of the sample cartridge. Gas would enter the cylinder at an orifice with a diameter of about 0.5 cm and would immediately impact the first layer of charcoal, which would have a diameter of 4.8 cm. The expected result for this flow path would be a fanning pattern as the molecules diffused into the charcoal. Within a short distance, the flow pattern would be expected to become relatively uniform across the entire diameter of the cylinder. Since the first sample would be about 2-cm thick, it is expected that the flow path would have been equalized to a uniform distribution prior to entering the second layer. The flow through the first layer would not be uniform across the diameter of the column and including these results in the mathematical fit would bias the results towards a non-uniform flow condition. Note again, however, that the result for the first layer was included when determining the total adsorbed activity in the cartridge and that exclusion was only used when determining the slope of the activity reduction curve.

4.2 HIGH CONCENTRATION MEASUREMENTS

The results for MSRECT001 indicated that essentially all measurable activity had been adsorbed within the first 7-in segment of the cartridge. The analytical results for the samples extracted from the cartridge are listed in Table 1 (p. 24). Considering that this was the first trial, and given the high amount of radon activity that was potentially available for removal in the auxiliary charcoal bed, there had been concern about exposure rates in the vicinity of the cartridge. In fact, the exposure rate at contact with the input end of the cartridge reached a maximum of about 100 mR h^{-1} within a few hours following both trials. Not having specific knowledge beforehand about what the exposure level may be, the experimental procedure required that the cartridge be allowed to decay for two days prior to retrieval. The lack of significantly measurable activity in the successive layers of the first sample was attributable, at least in part, to the delay time allowed between the stop of sampling and the counting of

the input sections to the cartridge. The delay was considered warranted due to both a lack of knowledge about the gradient of adsorbed activity and a concern for personnel exposure. The observed consequence, in retrospect, was that activity which had adsorbed onto latter sections of the sample cartridge decayed to the point of being non-detectable by the time of analysis.

The results for the second sample, which was referenced as MSRECT002, are given in Table 1 (p. 24). Calculations similar to those performed for the bench-scale tests were performed when analyzing the results. The activity residual following each layer was divided by the total activity that entered the cartridge and plotted as a function of depth as shown in Fig. 6B (p. 21). A significant observation for both samples was that a large input concentration did not appear to affect the adsorptive ability of the charcoal.

4.3 RADON AVAILABILITY IN THE URANIUM DEPOSIT

Of additional interest for the samples collected from the auxiliary charcoal bed at the MSRE was an estimate of the amount of radon that was available during sampling. The term *available* is used to define that amount of radon which would be immediately available for removal from the bed during the sampling operation and does not infer the total amount of radon that would be present in the deposit. The difference between what is being produced and that which is immediately removable by a flowing gas is assumed to be somehow trapped within the bed material (i.e., the charcoal itself).

The ^{220}Rn captured in the first sample from the uranium deposit resulted in a total measured ^{212}Pb activity of approximately 2 mCi. As discussed earlier, reported ^{212}Pb activities have been corrected to the time at which sample collection ceased. This is not the amount of ^{212}Pb that was present at that time, but is equivalent to the amount that would have been present if all adsorbed ^{220}Rn had instantly decayed at that time. Since the decay of ^{212}Pb during the 10-min sampling period would have been trivial, the total adsorbed ^{220}Rn activity for the sample would be equal to the original number of ^{212}Pb atoms multiplied by the ^{220}Rn decay constant, or equal to 1.4×10^3 mCi. The ^{220}Rn captured in the second sample produced a total measured ^{212}Pb activity of approximately 3 mCi, which correlates to a total adsorbed ^{220}Rn of 2×10^3 mCi and an input concentration to the cartridge of 9×10^9 pCi L^{-1} . Accounting for the initial purge of the volume prior to sample collection and assuming negligible losses of ^{220}Rn between the bed and the placement of the sample cartridge, the available equilibrium activity in the bed can be estimated as

$$P = \frac{A}{e^{-\lambda t}(1 - e^{-\lambda t})}, \quad (1)$$

where P is the production rate, A is the adsorbed activity, λ is the ^{220}Rn decay constant (0.76 min^{-1}), t is the sample collection time, and τ is the average transit time for radon atoms from the deposit to the sample cartridge during collection. Considering that an estimated 1-cm-diameter (3/8-in. I.D.) by 15-m-long (50-ft-long) transfer line was used, with volumetric transfer rates on the order of 15 L min^{-1} , the average transit time, τ , for radon atoms from the deposit to the sample cartridge would have been about 0.08 min.

The measured adsorbed ^{220}Rn values for samples MSRECT001 and MSRECT002 correlate to apparent *available equilibrium activities* in the deposit of 190 and 280 mCi, respectively. The difference between the values can at least be partly attributed to the lack of full measurement data for the first sample—therefore, the second value, or 280 mCi, is believed to be the more accurate of the two. A source term of this magnitude would produce *available* ^{220}Rn at a constant rate of approximately 3.7 mCi s^{-1} . The true equilibrium activity of ^{228}Th in the deposit is believed to be on the order of 9 Ci, which would be expected to produce ^{220}Rn at a rate of 110 mCi s^{-1} ; therefore, approximately 3% of the total radon is apparently available for removal by gas flow.

4.4 FISSION GAS AVAILABILITY IN THE URANIUM DEPOSIT

The samples collected from the MSRE uranium deposit were specifically designed for the determination of ^{220}Rn adsorption properties and source strength. In addition to ^{220}Rn progeny, some long-lived noble fission gases were also detected in the sample. Of these, the most prominent isotope was ^{133}Xe with a half-life of 5.3 days, which would presumably be produced in the deposit by fission—either spontaneous, alpha-neutron induced, gamma-neutron induced, or a combination of the three. The relatively long half-life of ^{133}Xe allowed measurements of this nuclide to be collected over the time period used for evaluating ^{220}Rn progeny. The measurement results for other nuclides were less consistent, but only noble gases and their progeny were detected. It should also probably be noted that $^{133\text{m}}\text{Xe}$ was typically detected in the samples at a relative concentration less than 10% of the measured ^{133}Xe .

The total amount of ^{133}Xe that was adsorbed onto each of the 10-min samples was $6 \times 10^4 \text{ pCi}$ with the collection efficiency for each sample estimated to be $>99.9\%$. This amount of adsorbed activity would require an *available* ^{133}Xe production rate in the deposit of $6 \times 10^3 \text{ pCi min}^{-1}$, which would eventually produce an *available equilibrium activity* in the deposit of $7 \times 10^{-5} \text{ Ci}$. As for the previously discussed ^{220}Rn availability, the latter value represents the amount of activity that would be available for immediate removal by gas flow if a full equilibrium condition for the isotope was established, but does not include any amount that could be bound within the charcoal deposit.

4.5 MEASUREMENT UNCERTAINTIES

There are many factors that could have affected uncertainties associated with measurements; however, the primary sources would have been expected in flow rate and gamma spectrometry measurements. A detailed evaluation of these was not performed for this report; however, a qualitative overview of expected magnitudes was constructed to provide insight into the overall accuracy of the results.

Flow rate measurements during sample collections at the MSRE were performed using a glass-view rotameter that had been calibrated with air under standard conditions. Corrections were required for the specific gravity, which for helium is 0.147 relative to air,

and for pressure differences. Pressure measurements were performed at both the input and exit to the sample collection system, as depicted in Fig. 3 (p. 18). The two primary sources of error here were the calibration and reading of the rotameter and whether or not the gas pressure inside the rotameter was in fact equal to what was observed at the exit from the cartridge.

The rotameter calibration would have been to within a few percent, while the actual visual reading could have introduced relative error on the order of 10%. The pressure drop across the sample cartridge itself was measured during bench scale measurements at similar flow rates and was found to be insignificant. In fact, the primary pressure drop between the pump and the input to the sampling loop was apparently occurring at the particulate pre-filter which was equipped with a 0.8 μm membrane disc. It was therefore concluded that the primary source of error for flow measurements at the MSRE would have been the visual reading of the rotameter.

Flow rate measurements during the bench scale tests were performed with a wet-test meter. This is an absolute, volumetric displacement device with extremely high accuracy when properly prepared that can be reliably used as a primary calibration standard. The pressure drop between the input to the wet-test meter and output of the sample cartridge during the bench-scale measurements was on the order of 1 cm of water, which is trivial when considering density corrections. It could therefore be concluded that the relative error associated with flow rate measurements during the bench-scale tests were probably less than a few percent.

Gamma spectrometry results could have error associated with the sample homogeneity, the equipment counting statistics, and also the calibration process itself. The amount of activity adsorbed during all measurements was very high, so that counting statistics were good with typical uncertainties on the order of 20 to 25% at the 95% (2σ) confidence level. The calibration standard was made by suspending a multi-nuclide primary standard solution onto a charcoal matrix and subsequently mixing it into a larger charcoal volume until homogenous. The overall error on the primary calibration solution was a few percent and the mixing process would have introduced very little error; probably on the order of 1 to 3%. As for homogeneity concerns, this is difficult to estimate, but considering that all samples were mixed uniformly by repeated tumbling, it would be a small concern in the overall scheme.

5. PROPOSED CHARCOAL FILTER DESIGN

A charcoal adsorber, or filter, design has been proposed for the purpose of capturing noble gases that are expected to be released during remediation operations. In particular, the presence of ^{220}Rn is a primary concern in the uranium deposit since the relative activity for this isotope far exceeds that of the other radioactive noble gases that are present. A design schematic for the proposed housing is shown in Fig. 7 (p. 22). The design would use a charcoal column in the shape of a right circular cylinder having a diameter of 43 cm and a length of 91 cm (17 in. I.D. \times 3 ft.). For this design, a flow rate through the adsorber housing of 28.3 L min^{-1} ($1 \text{ ft}^3 \text{ min}^{-1}$) will produce an average linear velocity of 0.32 cm s^{-1} (0.63 ft min^{-1}).

5.1 FILTRATION EFFECTIVENESS

The task calls for removal of the deposit by vacuuming out the charcoal and passing the stream through a solids separator. The gas and suspended residuals will be passed through a particulate filtration system and will then be passed through the charcoal adsorber for removal of ^{220}Rn . The maximum flow rate that is anticipated to pass through the adsorber is approximately $1.1 \times 10^3 \text{ L min}^{-1}$ ($40 \text{ ft}^3 \text{ min}^{-1}$), which corresponds to a velocity of 13 cm s^{-1} (26 ft min^{-1}). Allowing for a flow rate that is 50% higher than what is actually expected would result in a conservatively estimated superficial velocity of 20 cm s^{-1} (39 ft min^{-1}).

The results for measurements described in this report can be applied to the proposed design to calculate the expected decontamination factor as a function of input flow velocity. Measured tenth-value layer (TVL) values are summarized in Table 2 (p. 25) for all measurements and are also plotted versus flow velocity in Fig. 8 (p. 23). The table lists the measured TVL, flow velocity, and the predicted reduction factor after passing through a 3-ft-thick column of charcoal. Review of the results indicate a relatively constant TVL of about 10 cm (4 in.) at flow rates ranging from 10 to 33 cm s^{-1} (20 to 65 ft min^{-1}), with a single exception occurring at a flow rate of 18 cm s^{-1} (35 ft min^{-1}). For reasons unknown, the TVL at this velocity is about 50% larger than at the other measured rates. This could be due to any number of reasons, but the most probable is that some type of flow pattern transition is occurring at this velocity inside the 4.8-cm-diameter, charcoal-filled tube. Since this effect could not be explained, a TVL value of 15 cm (6 in.) was selected as a conservative point when analyzing the proposed adsorber. Using this factor for 91-cm (3-ft) of charcoal yields a reduction factor of 1×10^6 .

The output concentration observed from the uranium deposit indicated an *available* ^{220}Rn production rate of about $3.5 \times 10^{-3} \text{ Ci s}^{-1}$. It is not possible to say whether more radon would be available if the physical geometry of the deposit were changed, as will happen during remediation. Taking a conservative vantage point, the effectiveness of the proposed adsorber design was evaluated by assuming that the production rate of available ^{220}Rn in the deposit

would be 0.1 Ci s^{-1} . This value reflects an assumption that essentially all radon produced is actually available for removal and is a factor of more than 30 times what is actually expected.

Given a production rate of 0.1 Ci s^{-1} , a flow rate during vacuuming operations of $1.1 \times 10^3 \text{ L min}^{-1}$ ($40 \text{ ft}^3 \text{ min}^{-1}$) will result in a maximum output concentration from the deposit of $5 \times 10^{-3} \text{ Ci L}^{-1}$. After passing through the charcoal adsorber, the concentration for this scenario is anticipated to be reduced to less than $5 \times 10^{-9} \text{ Ci L}^{-1}$ when a TVL of 15 cm (6 in.) is assumed. Selecting a flow rate through the deposit of $1.7 \times 10^3 \text{ L min}^{-1}$ ($60 \text{ ft}^3 \text{ min}^{-1}$), as a second point of analysis, and performing a similar calculation predicts that the maximum output concentration from the deposit would be $4 \times 10^{-3} \text{ Ci L}^{-1}$. After passing through the charcoal adsorber, this concentration would be reduced to about $4 \times 10^{-9} \text{ Ci L}^{-1}$. It is emphasized that these output concentrations are based on what is believed to be both a high estimate of the available radon and an underestimate of the probable capability of the adsorber housing, and that the true output concentrations will likely be lower by a factor of about 1×10^4 .

5.2 FILTER CAPACITY

The lifetime of a charcoal adsorber can be estimated by considering its adsorptive capacity, which is a direct function of the number of radon plus competing atoms that can be retained within the porous structure. Based on data presented by Watson (Watson et al. 1988) and Gray (Gray and Windham 1987), Blue determined that a reasonable estimate for the number of adsorption sites in activated charcoal would be about $6 \times 10^{21} \text{ cm}^{-3}$. This value was based on measurements of ^{222}Rn adsorption using U.S. Environmental Protection Agency (Gray and Windham 1987) measurement canisters. Unfortunately, the specific type of charcoal used when determining this factor was not given; however, coconut-based forms are common for this application.

A second estimate of site density can be derived by evaluating the pore space volume. An estimate of the limiting pore volume in charcoal is quoted as ranging from 0.4 to $0.8 \text{ cm}^3 \text{ g}^{-1}$ (Scarpitta 1995), which is interpreted to mean the active volume that is available for adsorption. To estimate the adsorption site density for a pore volume of $0.6 \text{ cm}^3 \text{ g}^{-1}$, consider a case where pure radon fills the entire space. Radon has a liquid density of 4.4 g cm^{-3} at -62°C , therefore the radon atom density for this extreme case would be $3 \times 10^{21} \text{ cm}^{-3}$. Admittedly, this value is a very rough estimate since it has been calculated by assuming that the entire pore volume is filled with liquid radon. However, the value is in agreement with what was reported by Blue and is derived on a completely different premise and therefore helps to confirm his estimate. Considering that the decay products of radon have much higher physical densities, this magnitude of capacity is probably reasonable.

Considering the 55-s half-life of ^{220}Rn , there will be 2.9×10^{12} atoms per Ci of the isotope. The adsorptive ability of a charcoal volume will decrease with the number of available sites, but no appreciable effect would be observed until the number of sites expended comes within the same order of magnitude as the total number originally available. The overall effectiveness of the proposed adsorber can therefore be roughly evaluated by assuming that

all ^{220}Rn entering the system will be adsorbed within the first inch of charcoal. This is a conservative assumption, since all radon entering the bed will certainly not be adsorbed within the first inch.

For a 1-in.-thick layer of charcoal with a diameter of 17 in., the total number of available sites prior to operation will be about 1×10^{25} if the site density given by Blue is used. The assumption is now asserted that the adsorptive ability for the entire adsorber bed will begin at about the time that the number of adsorption sites in the first 1-in. layer is depleted by 1%, or down to 9.9×10^{24} sites. For this to occur, a total of 1×10^{23} sites will have to be exhausted. Since there will be one original radon atom for each site, this equates to a total adsorbed activity of about 3×10^{10} Ci. Rounding down gives a total estimated capacity, prior to the onset of degradation, of about 10^{10} Ci. Note that this is the amount of activity that would begin to degrade the overall effectiveness of the adsorber; however, the actual life would be much longer. The overall filtration effectiveness will decrease past this point, but the effectiveness would still be relatively high for quite some time. Considering the magnitude of this estimated capacity, it is concluded that degradation of performance during typical operations would most likely occur as the result of causes other than ^{220}Rn adsorption.

5.3 EFFECT OF TEMPERATURE, HUMIDITY, AND OTHER GASES

The prior discussions of effectiveness and capacity did not account for adsorption sites being depleted by means other than radon, nor did it account for effects of temperature. A concern for a charcoal bed when filtering air is the competition for sites by water molecules. It is best to avoid humid conditions since operation in dry atmospheres will alleviate concerns for the effect of water on the charcoal bed. Since this will not usually be possible, proper consideration should be given to possible water effects when predicting adsorber performance. The presence of other noxious gases will also compete with the radon and can easily poison the performance characteristics of a charcoal adsorber bed.

At standard temperature and pressure, there will be about 4 μg of water for every cubic centimeter of air when the relative humidity is about 50%, equating to about 10^{17} molecules of water per cubic centimeter. Unlike ^{220}Rn , which will exhaust sites following decay due to the fact that the daughter products are not mobile, water will be continually adsorbed and desorbed until a steady-state condition is reached. According to Blue, 50% relative humidity in air at standard conditions will result in about 5×10^{20} sites per cm^3 being occupied by water molecules after steady state has been reached. Considering that there are about $6 \times 10^{21} \text{ cm}^{-3}$ total sites available, this equates to about 10% potentially being depleted by the water at 50% relative humidity.

Operation with moist air at higher temperatures, where the absolute humidity could be higher, could potentially degrade adsorptive ability significantly. Note however, that even under conditions of saturation humidity, radon will still be retained and that the adsorptive ability for radon will not be reduced to zero by the presence of water. As an example of this effect, Pojer (Pojer et al. 1990) demonstrated by laboratory measurements that the adsorptive ability of charcoal for ^{222}Rn was reduced by about a factor of three when the relative humidity

was increased from 15% up to 90% at a room temperature of 35°C. As a point of comparison, it was also demonstrated that a change of relative humidity from 20% up to 50% decreased the effective performance by less than 20% at a room temperature of about 20°C.

Temperature variations can affect the adsorption characteristics of charcoal appreciably. Ackley cites a number of references for measured values of ^{222}Rn adsorption coefficients, ranging from <1000 up to $>10,000 \text{ cm}^3(\text{STP}) \text{ g-atm}^{-1}$ for various charcoal types and varying temperature, humidity, and carrier gas conditions. A nominal value of about $2500 \text{ cm}^3(\text{STP}) \text{ g-atm}^{-1}$ was cited as a reasonable estimate at 20°C and 50% relative humidity. One referenced source listed a series of tests performed with varying carrier gases at temperatures from -18°C up to 120°C . Of particular interest here is the expected change of effectiveness, and likewise capacity, if the temperature were to vary significantly from the roughly 20°C to 30°C conditions that were present when collecting measurements during this study. According to the summaries given by Ackley, a change of temperature from 20°C up to 50°C could be expected to decrease the adsorption coefficient by as much as a factor of two. This would correlate to a reduction in adsorptive effectiveness for the proposed 3-ft adsorber housing by a factor of 40. Similarly, a decrease of temperature to 0°C would result in an increase in the adsorption coefficient of about a factor of 2 equating to an increase in effectiveness for the proposed 3-ft adsorber housing by about a factor of 40. Note that the expected changes in effectiveness were calculated using the model by Ackley.

There are many other gases that can compete with radon for adsorption onto a charcoal bed. Of particular concern are organic gases and some large inorganic molecules such as CO_2 . Ackley indicates that, according to one citation, the adsorption coefficient for radon was reduced by a factor of about 6 in the presence of a pure CO_2 carrier gas. This is not likely to be a common scenario; however, it should be noted as an important consideration. A more likely event would be the presence of low concentrations of vapors and gases associated with various processes. Adsorption of these *poisons* can decrease both the effectiveness and the capacity of a charcoal bed for ^{220}Rn , but only under extreme conditions would it be expected to incapacitate it.

5.4 POTENTIAL HAZARDS

The use of charcoal will present two immediate hazards that should be considered. The first is ignitability and the second is associated with radiation exposure during operations. Specific evaluation of these hazards is not within the scope of this paper; however, the primary issues are quickly summarized as follows:

- charcoal is a flammable solid, which could present an explosion hazard when mixed with a highly oxidant material, and
- adsorption of ^{220}Rn can potentially generate significant radiation fields in the vicinity of the housing. The primary exposure will be caused by ^{212}Pb and ^{208}Tl , which will grow into equilibrium during extended operations. Upon stopping use, the exposure rate would decay at the rate of ^{212}Pb , with a half-life of about 11 hours.

6. SUMMARY

Measurements have been collected with the purpose of evaluating the effectiveness of activated charcoal for the removal of ^{220}Rn from process off-gas at the MSRE. A series of bench-scale tests were performed at superficial flow velocities of 10, 18, 24, and, 33 cm s^{-1} (20, 35, 47, and 65 ft min^{-1}) with a continuous input concentration of ^{220}Rn in the range of $9 \times 10^3 \text{ pCi L}^{-1}$. In addition, two tests were performed at the MSRE facility by flowing helium through the auxiliary charcoal bed uranium deposit. These tests were performed so that the adsorptive effectiveness could be evaluated with a relatively high concentration of ^{220}Rn . The results for all but one of the measurements are summarized in Table 2 (p. 25) and displayed in Fig. 8 (p. 23).

In addition to measuring the effectiveness of activated charcoal as a ^{220}Rn adsorption media, the source term for available ^{220}Rn and gaseous fission products was evaluated and compared to what is believed to be present in the deposit. The results indicate that only a few percent of the total ^{220}Rn in the deposit is actually available for removal and that the relative activity of fission gases is very small when compared to ^{220}Rn . Note that the estimate of availability is based on an assumed mass of uranium, which cannot be easily verified; therefore, the exact percentage should not be treated with more significance than is warranted.

The measurement data were then used to evaluate the expected effectiveness of a proposed charcoal adsorption bed consisting of a right circular cylinder having a diameter of 43 cm and a length of 91 cm (17 in. I.D. \times 3 ft.). The majority of the measurement data predicts an overall ^{220}Rn activity reduction factor of about 1×10^9 for such a design; however, two measurements collected at a flow velocity of 18 cm s^{-1} (35 ft min^{-1}) indicated that the reduction factor could be as low as 1×10^6 . The adsorptive capacity of the proposed trap was also evaluated to determine the expected life prior to degradation of performance. Taking a conservative vantage point during analysis, it was estimated that the adsorption effectiveness should not begin to deteriorate until a ^{220}Rn activity on the order of 10^{10} Ci has been processed. These values are based on the assumption that the carrier gas being filtered is relatively dry, or non-humid. Significant amounts of water would be expected to degrade the effectiveness of the charcoal for adsorption of radon. The effects of temperature and other noxious gases was also discussed with the purpose of indicating possible effects which could be observed. Based on this analysis, it was decided that degradation of performance for such a filter would most likely occur as the result of causes other than filling by radon progeny.

7. REFERENCES

- Ackley, R. D. 1975. *Removal of Radon-220 from HTGR Fuel Reprocessing and Refabrication Off-Gas Streams by Adsorption (Based on Literature Survey)*, ORNL-TM-4883, Oak Ridge National Laboratory.
- Blue, T. E., M. S. Jarzempa, and A. W. Fentiman. 1995. *Steady-State Response of a Charcoal Bed to Radon in Flowing Air with Water Vapor*, Health Physics 68(6): 809-816.
- Dubinin, M. M. 1972. *Fundamentals of the Theory of Physical Adsorption of Gases and Vapours in Micropores*, Adsorption-Desorption Phenomena, Proceedings of the II International Conference held at Florence in April 1971, ed. by F. Ricca, Academic Press Inc., ISBN: 0.12.587750.1.
- Gray, D. J., and S. T. Windham. 1987. *EERF Standard Operating Procedure for Rn-222 Measurement Using Charcoal Canisters*, Report No. EPA 520-5-005, U. S. EPA Office of Radiation Programs, Montgomery, Ala.
- Hawley, G. G. 1977. *The Condensed Chemical Dictionary*, Litton Educational Publishing, Inc., ISBN: 0-442-23240-3.
- Kocher, D. C. 1981. *Radioactive Decay Data Tables; A Handbook of Decay Data for Application to Radiation Dosimetry and Radiological Assessments*, DOE/TIC-11206, U.S. Department of Energy.
- ORNL (Oak Ridge National Laboratory). 1995. *Measurement Applications and Development Group Guidelines*, ORNL-6782, Oak Ridge National Laboratory.
- Pojer, P. M., J. R. Peggie, R. S. O'Brien, S. B. Solomon, and K. N. Wise. 1990. *Performance of a Diffusion Barrier Charcoal Adsorption ²²²Rn Monitor Under Conditions of Varying Humidity and Temperature*, Health Physics 58(1): 13-19.
- Scarpitta, S. C. 1995. *A Theoretical Model for ²²²Rn Adsorption on Activated Charcoal Canisters in Humid Air Based on Polanyi's Potential Theory*, Health Physics 68(3): 332-339.
- Watson, J. E., W. C. Adams, Y. Xie, S. W. Fong, and H. J. Newman. 1988. *Survey of ²²²Rn in North Carolina Homes*, Health Physics 55:71-75.

^{232}U Decay Series

Nuclide	Half Life	Major Radiation Energies (MeV) and Intensities [†]		
		α	β (max)	γ
$^{232}_{92}\text{U}$ ↓	72 y	5.32 (68.6%) 5.27 (31.2%)	—	0.058 (0.2%)
$^{228}_{90}\text{Th}$ ↓	1.9 y	5.43 (72.7%) 5.34 (26.7%)	—	0.084 (1.2%)
$^{224}_{88}\text{Ra}$ ↓	3.6 d	5.68 (95.1%) 5.45 (4.9%)	—	0.241 (4.0%)
$^{220}_{86}\text{Rn}$ ↓	56 s	6.29 (100%)	—	—
$^{216}_{84}\text{Po}$ ↓	0.15 s	6.78 (100%)	—	—
$^{212}_{82}\text{Pb}$ ↓	10.6 h	—	0.16 (5.2%) 0.33 (85%) 0.57 (9.9%)	0.239 (45%) 0.300 (3.4%)
$^{212}_{83}\text{Bi}$ ↓	61 m	6.05 (25%) 6.09 (10%)	0.63 (3.4%) 0.73 (2.6%) 1.52 (8.0%) 2.25 (48.4%)	0.040 (2%) 0.727 (7%) 1.620 (1.8%)
$^{212}_{84}\text{Po}$ (64%) ↓ $^{208}_{81}\text{Tl}$ (36%) ↓	300 ns	8.78 (100%)	—	—
$^{208}_{81}\text{Tl}$ ↓	3.1 m	—	1.28 (25%) 1.58 (21%) 1.80 (50%)	0.511 (23%) 0.583 (86%) 0.860 (12%) 2.614 (100%)
$^{208}_{82}\text{Pb}$	STABLE	—	—	—

[†] Intensities refer to percentage of decays of the nuclide itself.
Radiations with emission intensities less than 1% excluded.

Fig. 1. Decay chain for ^{232}U . The table was compiled from decay data tables published by Kocher (Kocher 1981).

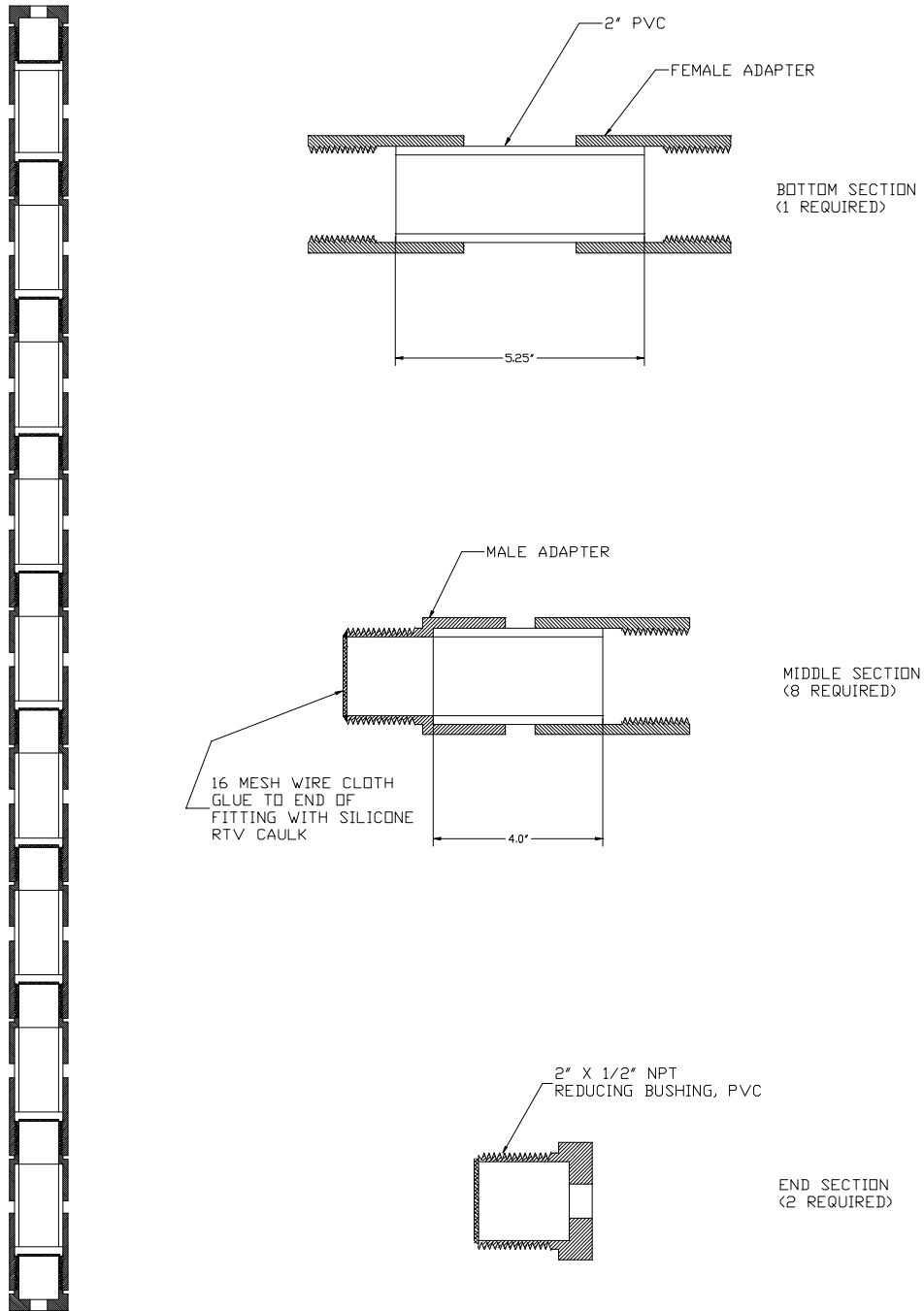

Fig. 2. Design schematic of the charcoal cartridge used when sampling ^{220}Rn from the uranium deposit in the charcoal bed at the MSRE. *Not to scale.* (Courtesy of Robert Campbell).

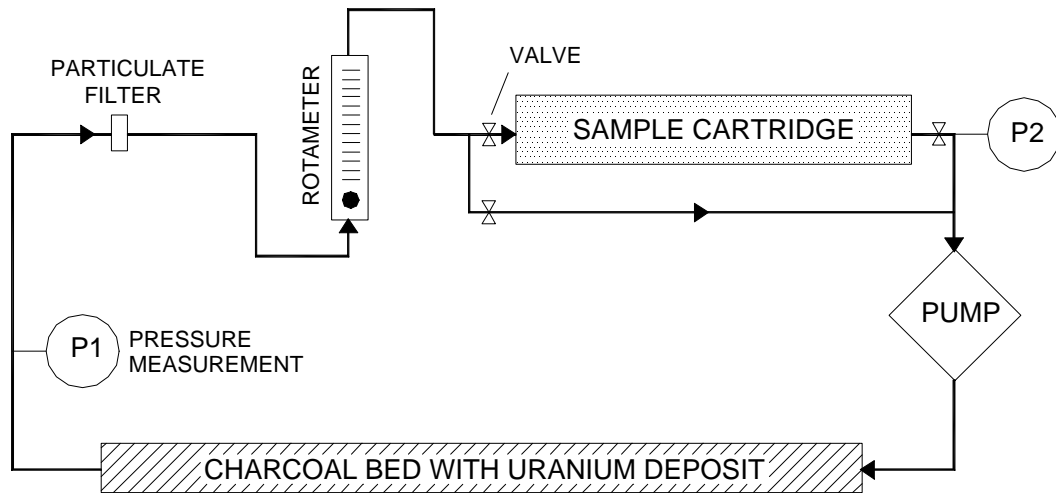

Fig. 3. Simplified schematic of flow diagram for testing of radon adsorption from the uranium deposit in the auxiliary charcoal bed at the MSRE. The points on the figure labeled *P1* and *P2* indicate pressure measurement points that were referenced to correct observed flow rate readings at the rotameter.

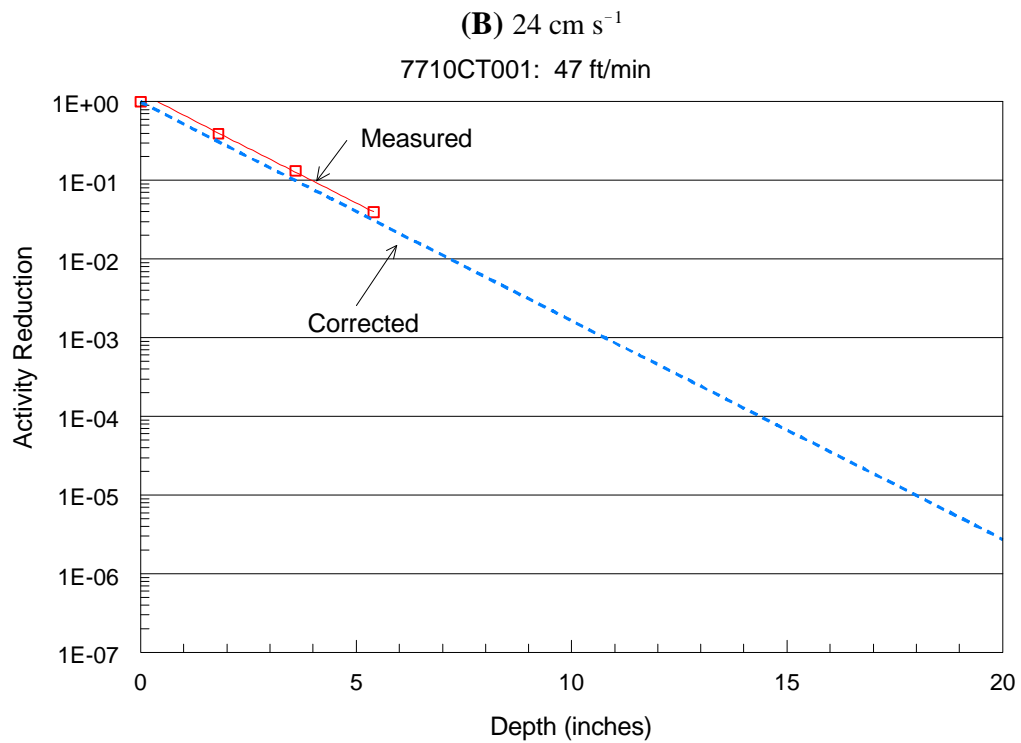
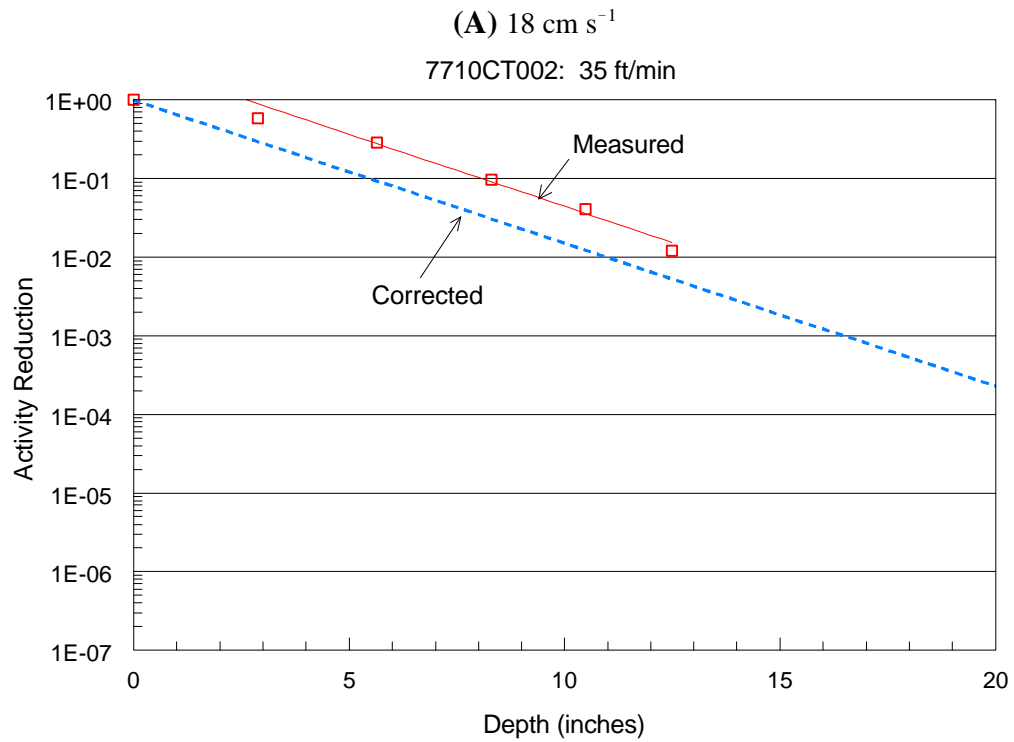

Fig. 4. Results for ^{220}Rn adsorption tests at low input concentrations with velocities of 18 cm s^{-1} (35 ft min^{-1}) and 24 cm s^{-1} (47 ft min^{-1}). The markers represent actual measurement data, the solid lines show a logarithmic fit to the measurement data, and the dashed lines (indicated as *corrected*) show a line with a y-intercept of one and a slope equal to that of the logarithmic fit.

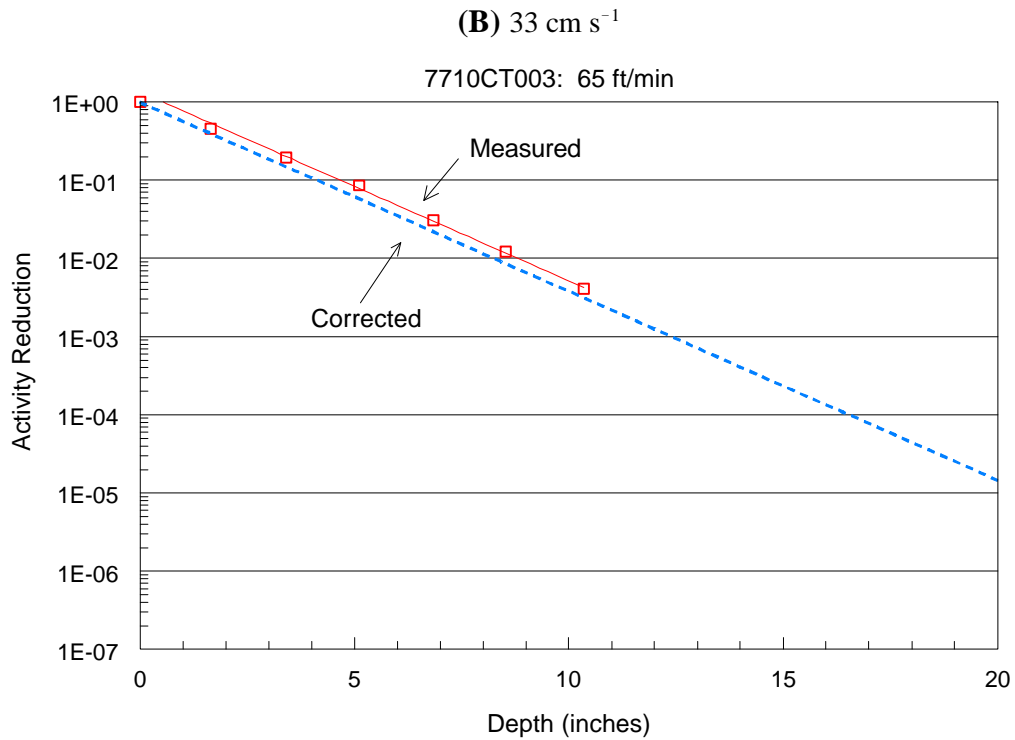
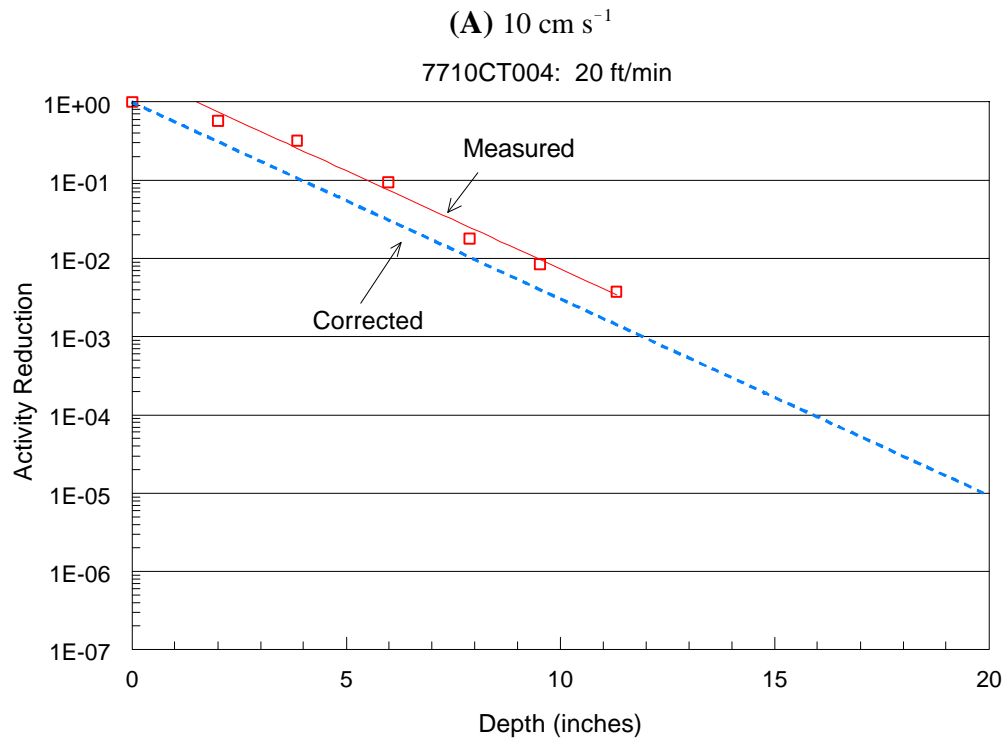

Fig. 5. Results for ^{220}Rn adsorption tests at low input concentrations with velocities of 10 and 33 cm s^{-1} (20 and 65 ft min^{-1}). The markers represent actual measurement data, the solid lines show logarithmic fits to the measurement data, and the dashed lines (indicated as *corrected*) show lines with a y-intercept of one and a slope equal to that of the logarithmic fit.

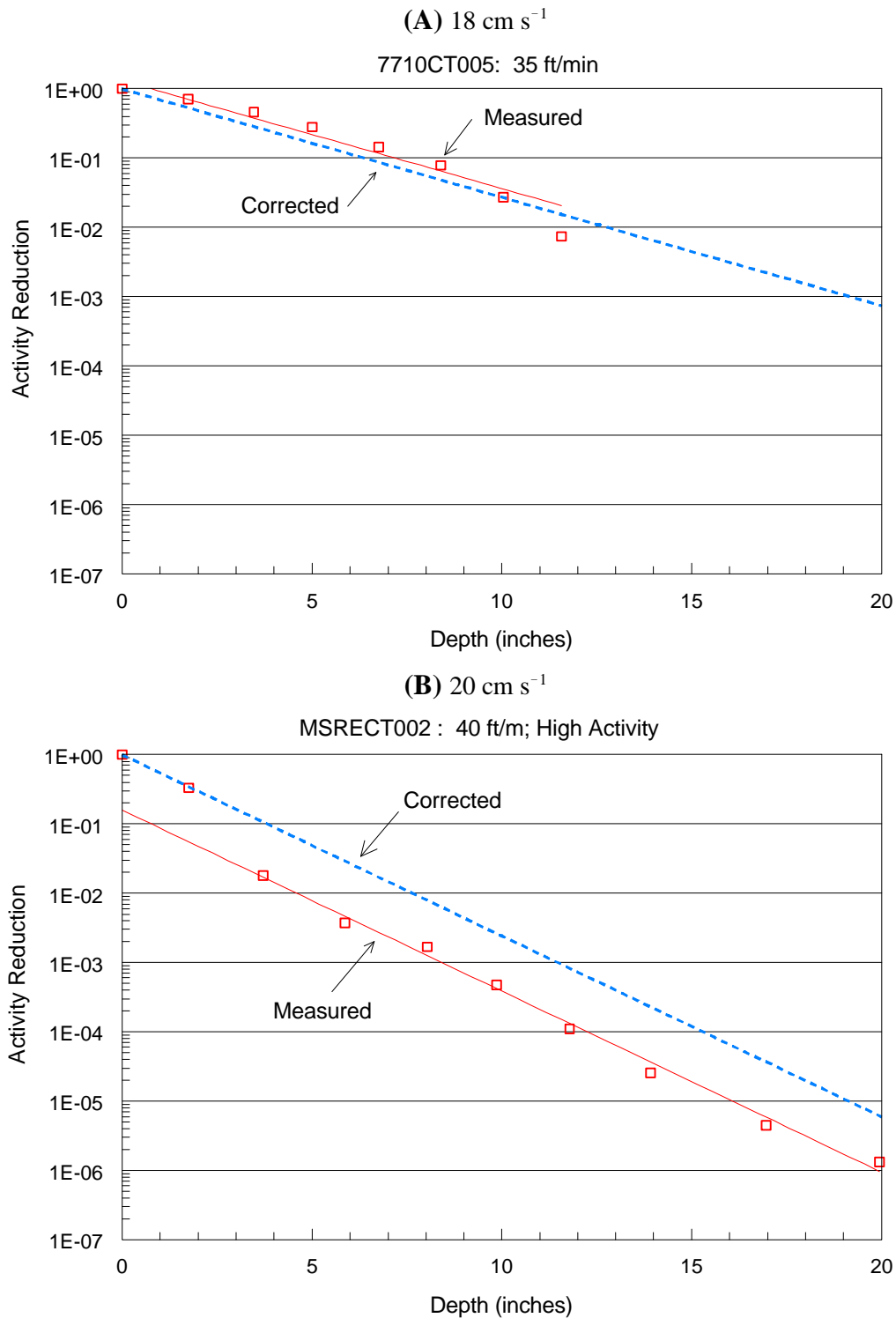

Fig. 6. Results for ^{220}Rn adsorption tests at (A) a low input concentration with a velocity of 18 cm s^{-1} (35 ft min^{-1}) and (B) a high input concentration with a velocity of 20 cm s^{-1} (40 ft min^{-1}). The markers represent actual measurement data, the solid lines show logarithmic fits to the measurement data, and the dashed lines (indicated as *corrected*) show lines with a y-intercept of one and a slope equal to that of the logarithmic fit.

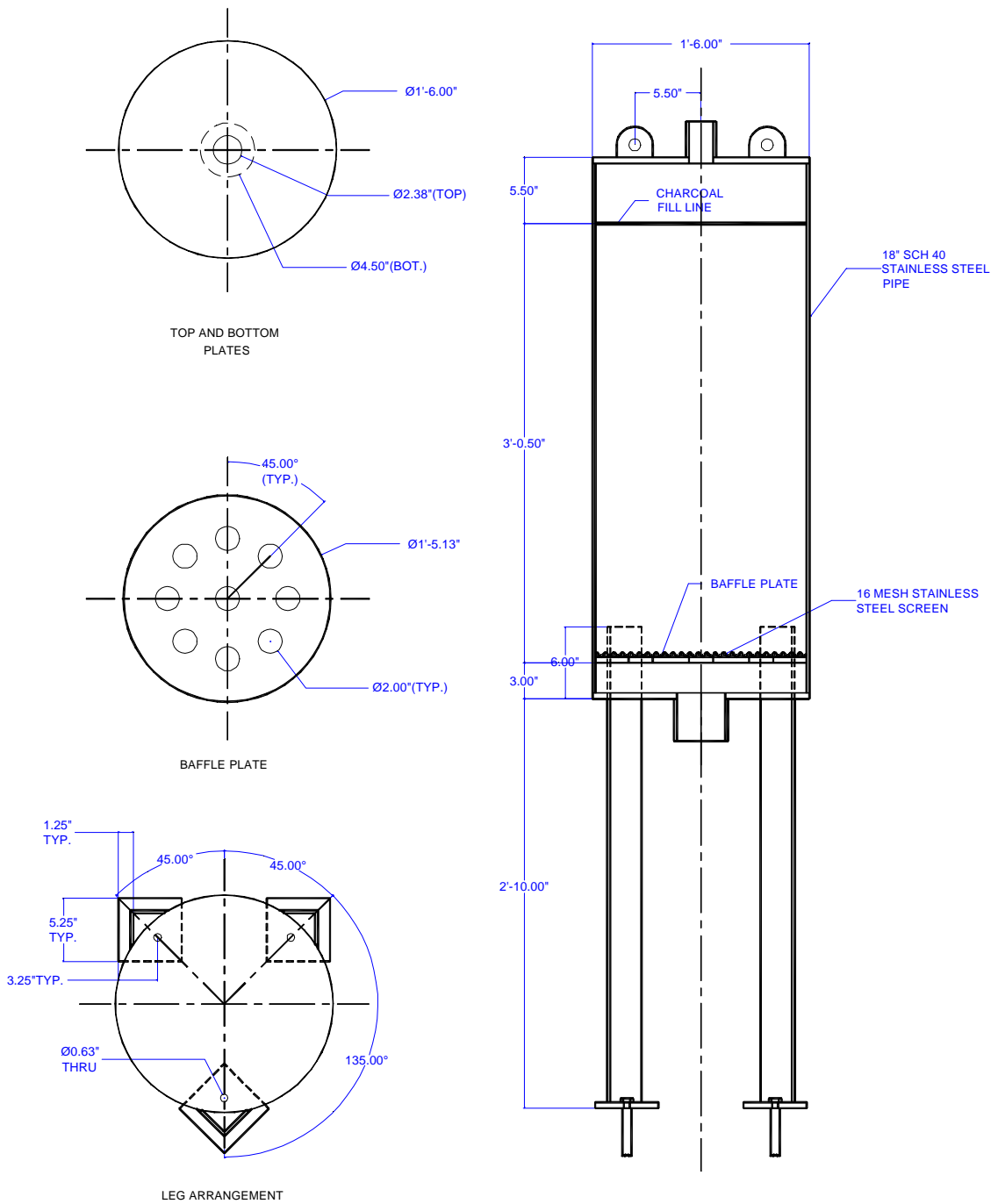

Fig. 7. Schematic of proposed charcoal filter to be used during uranium deposit removal from the auxiliary charcoal bed at the MSRE. (Courtesy of Robert Campbell.)

TVL vs Velocity

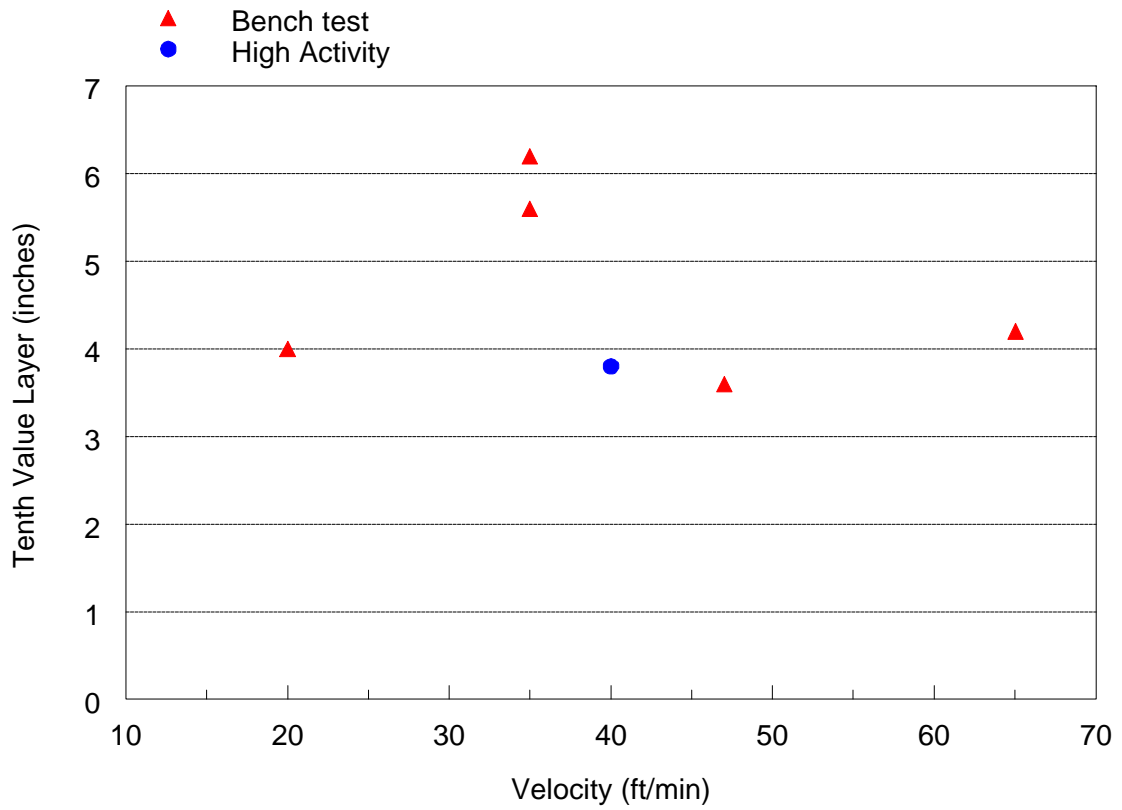

Fig. 8. Plot of measured TVL values versus flow velocity. The data used to create this chart are summarized in Table 2.

Table 1. Gamma spectrometry analysis results for charcoal adsorption tests at the MSRE

Sample No.	Analysis		Mass (g)	Pb-212		Cs-137		Xe-133		Xe-135	
	Date	Time		Measured (pCi g ⁻¹)	Decay corrected (total pCi)	Measured (pCi g ⁻¹)	Decay corrected (total pCi)	Measured (pCi g ⁻¹)	Decay corrected (total pCi)	Measured	Decay corrected
MSRECT001A	08/13/98	03:20 PM	127	9.7e+02	1.9E+09	nd	nd	130	3.7E+04	nd	nd
MSRECT001B	08/13/98	10:49 AM	109	3.4e-01	4.2E+05	0.13	1.1E+01	76	1.8E+04	nd	nd
MSRECT001C	08/13/98	09:32 AM	109	1.8e-01	2.1E+05	0.24	2.3E+01	28	6.6E+03	nd	nd
MSRECT001D	08/12/98	03:36 PM	109	1.6e-01	5.7E+04	nd	nd	8.2	1.8E+03	nd	nd
MSRECT001E	08/12/98	02:30 PM	109	nd	nd	nd	nd	1.8	3.8E+02	nd	nd
MSRECT001F	08/11/98	10:29 AM	109	3.1e-01	1.6E+04	0.25	2.4E+01	nd	nd	nd	nd
MSRECT001G	08/11/98	09:46 AM	109	nd	nd	0.23	2.2E+01	nd	nd	nd	nd
MSRECT001H	08/10/98	04:38 PM	110	3.4e-01	5.6E+03	0.3	3.0E+01	nd	nd	nd	nd
MSRECT001I	08/10/98	04:06 PM	156	1.4e+00	3.2E+04	0.28	3.9E+01	nd	nd	nd	nd
MSRECT002I-4	08/31/98	03:41 PM	32.4	2.2e+04	2.0E+09	nd	nd	194	1.2E+04	nd	nd
MSRECT002I-3	08/31/98	02:40 PM	36.1	9.6e+03	9.1E+08	nd	nd	214	1.5E+04	nd	nd
MSRECT002I-2	08/31/98	02:05 PM	39.5	4.1e+02	4.1E+07	1.1	4.2E+01	201	1.5E+04	nd	nd
MSRECT002I-1	08/31/98	10:29 AM	40	7.4e+01	5.9E+06	nd	nd	107	8.1E+03	nd	nd
MSRECT002H-3	08/28/98	04:26 PM	33.5	4.0e+03	3.5E+06	nd	nd	107	4.7E+03	nd	nd
MSRECT002H-2	08/28/98	04:03 PM	35.5	1.2e+03	1.1E+06	nd	nd	303	1.4E+04	11	3.9E+02
MSRECT002H-1	08/28/98	03:25 PM	39.3	2.5e+02	2.5E+05	nd	nd	238	1.2E+04	12	4.7E+02
MSRECT002G-2	08/27/98	03:13 PM	56.1	2.1e+02	6.2E+04	nd	nd	180	1.2E+04	49	2.8E+03
MSRECT002G-1	08/27/98	02:37 PM	54.9	3.4e+01	9.2E+03	0.67	3.5E+01	149	9.4E+03	43	2.4E+03
MSRECT002F	08/27/98	02:03 PM	111	6.9e+00	3.6E+03	0.47	4.9E+01	98	1.2E+04	32	3.6E+03
MSRECT002E	08/27/98	10:31 AM	109	2.6e-01	1.1E+02	0.42	4.3E+01	57	6.9E+03	24	2.6E+03
MSRECT002D	08/27/98	09:51 AM	109	nd	nd	nd	nd	40	4.9E+03	17	1.9E+03
MSRECT002C	08/27/98	09:11 AM	110	4.0e-01	1.5E+02	0.16	1.4E+01	23	2.8E+03	11	1.2E+03

nd = results were not detected at a significant level.

Table 2. Summary of measured tenth-value layers (TVL) for ^{220}Rn passing through activated charcoal

Sample ID	Relative input concentration ^a	Flow velocity cm s^{-1} (ft min^{-1})	TVL cm (in.)	Reduction factor ^b
7710CT004	LOW	10 (20)	10 (4.0)	1×10^9
7710CT002	LOW	18 (35) ^c	14 (5.6)	3×10^6
7710CT005	LOW	18 (35) ^c	15 (6.0)	1×10^6
MSRECT002	HIGH	20 (40)	9.7 (3.8)	3×10^9
7710CT001	LOW	24 (47)	9.1 (3.6)	1×10^{10}
7710CT003	LOW	33 (65)	11 (4.2)	4×10^8

^a Data collected with either a low (bench-scale) ^{220}Rn concentration or a high ^{220}Rn concentration.

^b Predicted reduction factor for the proposed filter design (i.e., a 91-cm-long (3-ft) column of Calgon Carbon PCB-6×16 activated coconut-based charcoal).

^c Two separate measurements were collected at a velocity of 18 cm s^{-1} (35 ft min^{-1}) in order to confirm the larger TVL value.

INTERNAL DISTRIBUTION

- | | |
|--------------------|------------------------------|
| 1. S. N. Burman | 14. J. E. Rushton |
| 2-3. R. L. Coleman | 15. R. E. Swaja |
| 4. G. R. Eidam | 16. R. M. Szozda |
| 5. R. L. Faulkner | 17. S. N. Storch |
| 6. R. D. Foley | 18. M. S. Uziel |
| 7. M. H. Haghghi | 19. J. L. Westbrook |
| 8. A. P. Kelsey | 20. EMEF Document |
| 9. D. W. Malkemus | Management Center |
| 10. G. T. Mei | 21. MAD Records Center |
| 11. M. E. Murray | 22. Central Research Library |
| 12. F. J. Peretz | 23. Laboratory Records) RC |
| 13. D. W. Ramey | |

EXTERNAL DISTRIBUTION

- 24-25. Office of Scientific and Technical Information, U.S. Department of Energy, P.O. Box 62, Oak Ridge, TN 37831